

HKS700E

Operations Manual

Please read this manual before using.

Engine S/N: _____



2003 Sept
Ver.3.00

HKS CO.,LTD
7181 KITAYAMA FUJINOMIYA
SHIZUOKA
JAPAN 418-0192
TEL 0544-54-1781
FAX 0544-54-1410
hks_aviation@hks-power.co.jp
http://www.hks-power.co.jp/hks_aviation/

HKS 700E

CONTENTS

- 1 GENERAL
 - 1.1 Log of revisions.

- 2 HKS700E ENGINE
 - 2.1 Type designation.
 - 2.2 Specifications: HKS-700E.
 - 2.3 Views of the engine.

- 3 TECHNICAL DATA HKS-700E
 - 3.1 Dimensions and weights.
 - 3.2 Equipment.
 - 3.3 Performance.
 - 3.4 RPM limitations.
 - 3.5 Fuel consumption.
 - 3.6 Information about fuels and lubricants.
 - 3.7 The cooling system.
 - 3.8 Cylinder head temperatures.
 - 3.9 Propeller reduction unit.
 - 3.9.1 Propeller mass moment of inertia
 - 3.10 Exhaust gas temperature

- 4 PERFORMANCE CURVE

- 5 MANUAL OF INSTRUCTION HKS-700E
 - 5.1 Before starting the engine.
 - 5.2 Starting the engine.
 - 5.3 Warm up and run up.
 - 5.4 Take-off and climbing flight.
 - 5.5 Engine shutdown.
 - 5.6 Stopping the engine and restarting in flight.

HKS 700E

- 6 MAINTENANCE INSTRUCTIONS
 - 6.1 Daily inspection.
 - 6.2 Periodic checks.
 - 6.2.1 First 25-hour-check, 50-hour-check
 - 6.2.2 100-hour-check.
 - 6.2.3 200-hour-check.
 - 6.3 Preservation of the engine during storage
 - 6.4 Winter operation.
 - 6.4.1 Care of the electrical system.
 - 6.4.2 Cold starting.
 - 6.4.3 Carburetor icing.

- 7 MAINTENANCE
 - 7.1 Changing oil.
 - 7.2 Air intake filter (s).
 - 7.3 Compression test.
 - 7.4 Carburetor adjustment.
 - 7.4.1 Idle speed adjustment.
 - 7.4.2 Throttle cable adjustment.
 - 7.5 Spark plugs.
 - 7.6 Exhaust system.
 - 7.7 Bolts and nuts.
 - 7.8 Resistance of the electrical equipment.

- 8 OVERHAULS
 - 8.1 Thorough inspections (TBO).
 - 8.2 Major repairs and major modifications.

- 9 TABLE FOR TORQUE VALUES

HKS 700E

This is a non-certified aircraft engine; the possibility of engine failure exists at all times. Do not operate this engine over densely populated areas. Do not operate this engine over terrain where a safe, power off landing cannot be performed.

The operating and maintenance instructions supplied with this engine must be followed at all times. Flying any aircraft involves the risk of injury or death, building and maintaining your own aircraft requires great personal responsibility.

HKS 700E

2. HKS700E ENGINE

2.1. Type designation.

HKS-700E

1 2

1. Manufacturer: HKS.

2. Piston displacement in c.c.

2.2. Description of the HKS-700E.

Air-cooled, four-stroke.

Cylinder arrangement: 2 cylinders, horizontally opposed.

One central camshaft-pushrods-OHV, hydraulic lifters.

Oil cooled cylinder head.

Dual CDI (capacitive discharge ignition).

Electric starter.

Alternator.

Nickel ceramic composite coated cylinders.

Dry sump forced lubrication.

HKS 700E

2.3. Views of the engine.

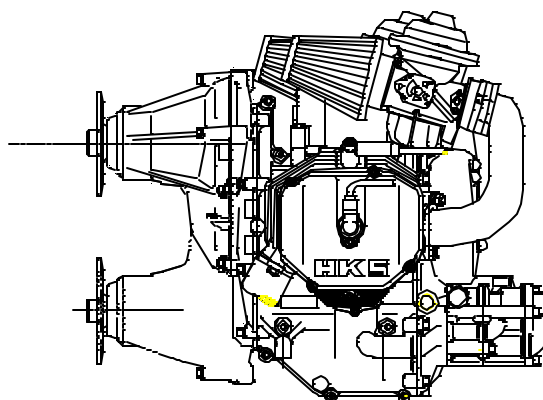
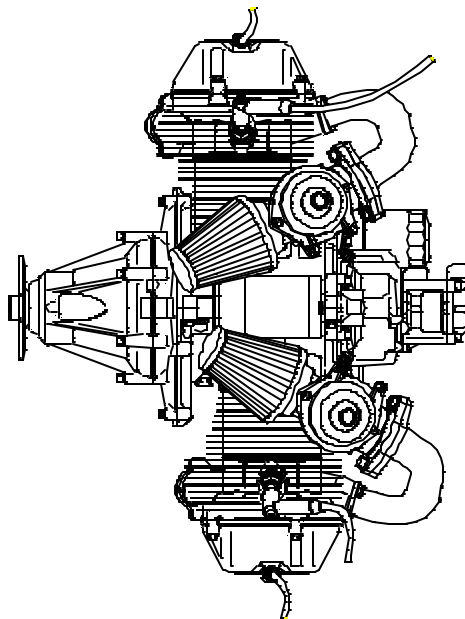
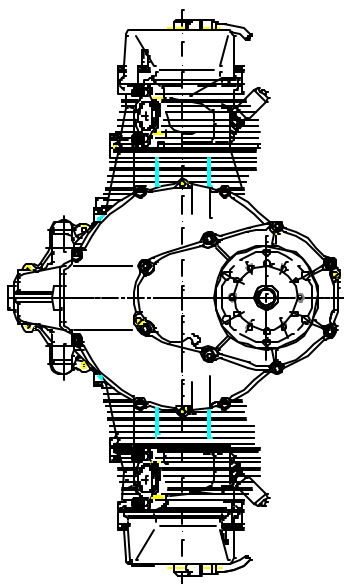

HKS 700E

3. TECHNICAL DATA HKS700E

3.1. Dimensions and weights.

| | |
|-----------------------------------|--|
| Bore: | 85 mm |
| Stroke: | 60 mm |
| Total piston displacement: | 0.680 L (680 CC) |
| Compression ratio: | 11.3:1 |
| Direction of crankshaft rotation: | Clockwise (Looking from pilot seat, tractor configuration.) |
| Direction of prop shaft rotation: | Counter clockwise |
| Weight: | Approx. 49kg (108LBS.) dry, with all electrical equipment, electric starter, carburetors and gearbox. |
| Weight: | Approx. 55kg (121 LBS.) total system, with exhaust, oil tank and oil cooler. |

3.2. Equipment

| | |
|-------------------------|---|
| Ignition unit: | Dual CDI (capacitive discharge type) |
| Ignition timing: | 10 DEG. B.T.D.C (below 2000r/min) 23 DEG. B.T.D.C (over 4000r/min) |
| Spark plugs: | DENSO IK24C11 |
| Electrode spacing: | 1.1 mm (.043") |
| Alternator performance: | 210W DC |
| Carburetor: | Bing CV Carb type 64/32 |
| Air filter: | K&N tapered. |
| Fuel pump: | Pneumatic, impulse from the intake. |
| Fuel filter: | Mesh type, 15 microns maximum. |
| Starter: | 12V/0.6kW, engagement via gear reduction and overrunning clutch. |

HKS 700E

3.3. Performance

| | |
|--------------------------|-------------------------------------|
| Take-off power (3 min.). | Approx. 44.7kW (60HP) at 6200 r/min |
| Max continuous power. | Approx. 41.7kW (56HP) at 5800 r/min |

3.4. RPM limitations

| | |
|------------------------|--------------------|
| Max. permissible r/min | 6200 r/min |
| Max. continuous r/min | 5800 r/min |
| Idle r/min | Approx. 1400 r/min |

3.5. Fuel consumption (With full throttle (loaded))

| | |
|--------------------------------------|-------------------|
| Consumption @ max. permissible r/min | 24 L/H (6.3 GPH.) |
| Consumption @ max. continuous r/min | 16 L/H (4.2 GPH.) |
| Consumption @ 75%: | 13 L/H (3.4 GPH.) |

HKS 700E

3.6. Information about fuels and lubricants

- Fuel: Automobile fuel, unleaded premium
92 Octane (RON) minimums.
- Fuel pressure: 15 - 40 kPa
(0.15 - 0.4 kgf/cm², 2.2 - 5.8 psi)
- Oil type: No aircraft engine oils.
Only multi-grade brand-name 100% synthetic
oils for automobile engines, according to
API-classification (API min. SJ).
Take the viscosity of the oil named with SAE at
least 15W-30, if available 5W-30 is highly
recommended.
0W-30 or 0W-40 is recommended in winter.
- Oil volume: 4 Liters (4.2 quarts)
This will vary based on the oil line layout and oil cooler size used.
- Oil level is between 1/2 and 2/3 of oil tank after 3 minutes idling.
- Oil consumption: Max. 0.1 L/h (1/10th quart per hour)
- Oil pressure: Min. 590 kPa (6.0 kgf/cm², 85psi) @ 6200 r/min
Min. 118 kPa (1.2 kgf/cm², 17 psi) @ idle r/min
- Oil temperature (readings off of the feed line into engine):
Min. 50 Deg.C (122 Deg. F)
Max. 120 Deg.C (248 Deg. F)
- Optimum oil temperature range: 80 - 100 Deg.C (170 - 212 F.)



CAUTION!

- Don't use any aircraft engine oils and additives.
- You must install the oil cooler in the return line to the oil tank.

HKS 700E

3.7. Cooling system

Free air-cooling.

For the engines with full-cowled engine installation, ducting is required to properly channel cooling air to the cylinders.

3.8. Cylinder head temperature

Max. permissible cylinder head temperature

(Measured on the hottest cylinder): 170 Deg. C (338 Deg. F)



CAUTION!

- Use the bayonet style CHT probe.

3.9. Propeller drive-reduction gear

Reduction ratio: crankshaft to prop shaft=2.58:1 or 3.47:1

Torsional shock absorption is based on progressive cushioning from an axial spring-loaded hub with dogs.

3.9.1. Propeller mass moment of inertia

Max. permissible propeller mass moment of inertia

2.58:1 3000 kg cm²

3.47:1 6000 kg cm²

3.10. Exhaust gas temperature

Max. permissible exhaust gas temperature

(Measured 20mm apart from exhaust flange): 760 Deg. C (1400 Deg. F)

HKS 700E

4. PERFORMANCE CURVE

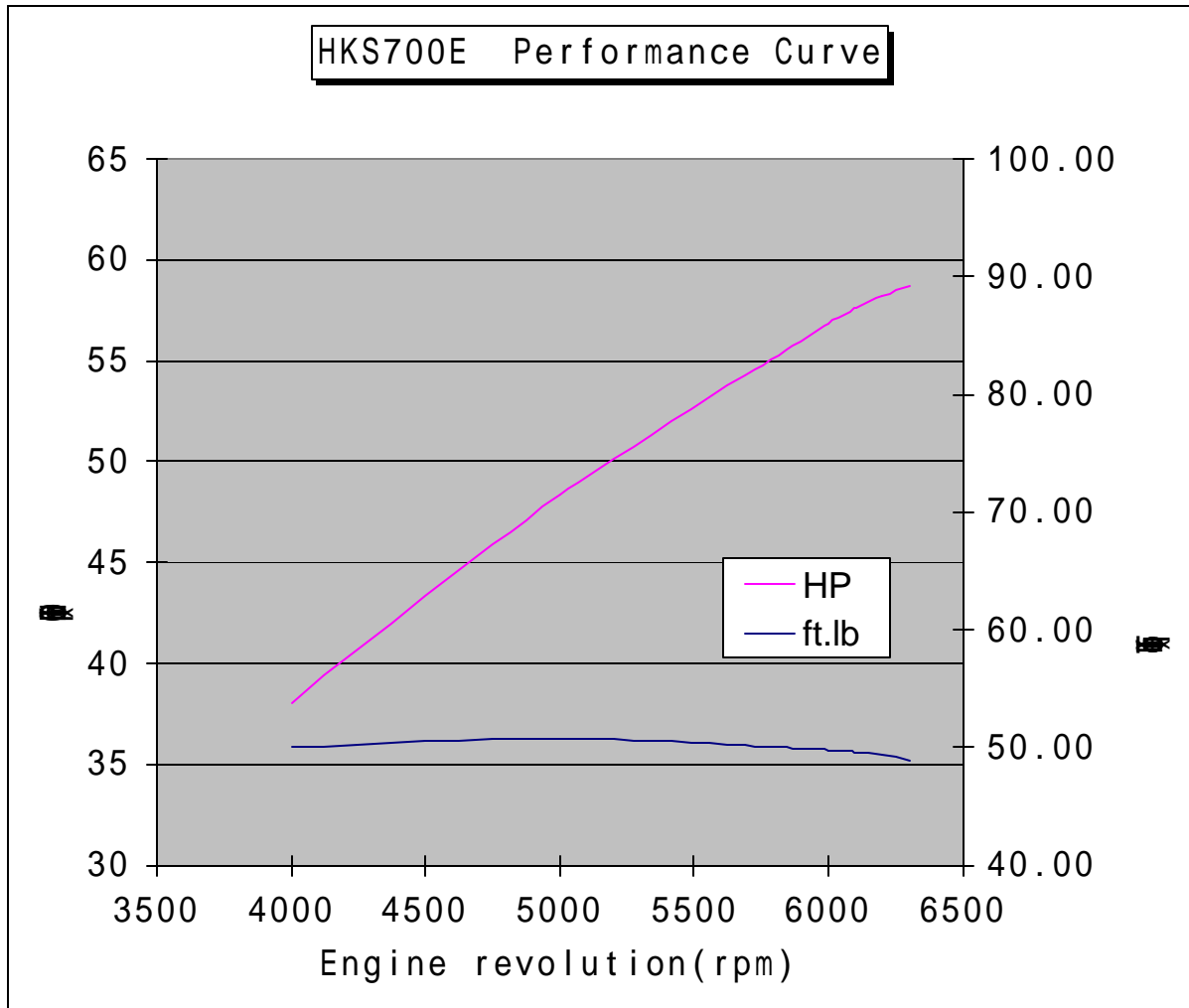

HKS 700E

5. OPERATING INSTRUCTIONS FOR THE HKS-700E

These instructions and procedures must be followed in detail for the proper operation of the engine and systems. To deviate from these instructions may lead to increased engine wear and a loss of reliability.

5.1. Before starting the engine

- With the aircraft chocked or tied down.
- Ignition "OFF"
- Has the daily check been done? (See Sec 6.1)
- Check the range and free movement of the throttle lever.
- Turn the propeller by hand; check the engine for unusual noises or hard movement.

5.2. Starting the engine

- Parking brake: Set (or aircraft chocked)
- Fuel shutoff valve: OPEN
- Choke: On (if necessary)
- Throttle: Closed
- Master switch: ON
- Ignition: Both ON
- Starter: Engage
- Let engine run at approx. 2000 r/min
- Oil pressure Check nominal. (See Sec 3.6)



CAUTION!

- Crank the starter for a maximum of 10 seconds only. If the engine does not start, a cooling down period of 3 minutes is required.
- Check the oil pressure after starting engine, if the indicated oil pressure is too low, stop the engine. Otherwise the engine will be damaged.

HKS 700E

5.3. Warm up and run up

- Let the engine run at 2000-3000 r/min for about 5 minutes so that the oil pressure will not exceed the 390kPa (57psi, 4bar) maximum during run up.
- Choke off (if used).
- Wait for the oil temperature to reach a minimum of 50 Deg. C (122 Deg.F) before taking off or running up to a high RPM.
- Perform a Mag check of the two ignition circuits at 3000 r/min.
- Engine must not stop during Mag check.

5.4. Take-off and climb

- Choke: OFF
- Advance the throttle smoothly and quickly to full throttle.
- Perform the take-off and initial climb in this position, and then reduce power slightly to the maximum continuous RPM, (See Sec. 3.3).

 **CAUTION!**

Observe RPM, oil temperature, cylinder head temperature, exhaust gas temperature and oil pressure. The limits must not be exceeded. If the temperatures are moving towards exceeding the described limitations, reduce engine power (if possible) and increase airspeed to improve engine cooling.

5.5. Engine shutdown

- Let the engine cool sufficiently.
- Throttle: IDLE
- Ignitions: OFF
- Master switch: OFF

 **CAUTION!**

After taxiing with high power, let the engine idle @ 2000 r/min for about 3 minutes.

HKS 700E

5.6. Engine shutdown and restarting in flight

- Let the engine cool at 3000 r/min for 30 sec.
- Throttle: IDLE
- Ignitions: OFF

The in-flight re-start procedure is the same as on the ground. Use choke if necessary.

HKS 700E

6. MAINTENANCE INSTRUCTIONS

6.1. Daily check

- Take off the engine cowling (if so equipped).
- Check the engine for missing or loose parts as well as for any wear.
- Check the condition of the ignition harness.
- Check the actuating mechanisms for throttle and choke, make certain that the action of the throttle is smooth.
- Check the oil level and fill if necessary. The oil level should be between 1/2 and 2/3rd of the oil tank dipstick after 3 minutes idle running.
- Check the oil and fuel system for any leakage.
- Drain the sump(s) to remove water in the fuel tank.
- Reattach the engine cowling if equipped.
- With the ignition off, turn the propeller by hand and check the engine for unusual noises or hard movement and proper compression.
- Before flight engine test run.

Observe the starting behavior. Let the engine warm up, monitoring the temperatures and pressures. Do a run-up observing the throttle response (adequate RPM acceleration) and a full-power run-up. (Maximum RPM depends on the type of propeller and pitch used)



DANGER!

1. Prior to turning the propeller by hand, confirm that.
The ignition and master switches are: OFF
The aircraft is chocked or properly tied down.
2. Cockpit operations must be performed by a trained person.

6.2. Periodic inspections

After the first 25 hours of operation the inspections listed in 6.2.1 are to be performed. The next inspection is due to at 50 hours and thereafter every 50 hours. The 100-hour inspection mentioned under 6.2.2 is to be performed every 100 hours but at least annually. The 200-hour inspection mentioned under 6.2.3 is to be performed every 200 hours.

HKS 700E

6.2.1. First 25-hour-inspection, 50-hour-inspection

- Check condition of the throttle cables, choke cables.
- Engine mounts. Check for cracks, looseness of mounts, and looseness of engine to mounts.
- Check for looseness of bolts, nuts and pins.
- Check for oil leaks from hoses, the oil tank and fittings.
- Perform an oil change.(See Sec 7.1)
- Check the magnet of oil drain screw for the metal contamination.
- Change the oil filter.
- Fuel lines-check the standoffs, safeties, leaks and wear.
- Fuel filter-check, clean.
- Check the ignition harness for damage and tight connections at spark plug cap.
- Air filter-check, clean.
- Check the mounting of the carburetors and the insulator rubber for cracks.
- Check the general condition of the exhaust system; look for cracks, particularly at the welds.
- Check the muffler and attaching flanges at the exhaust ports on the cylinders for exhaust leaks.
- Check the ignition coils for wear and security of attachment.
- Check for leaks at the oil pressure and temperature sensors.
- Electrical wiring-check for wear, damage and security of attachment.
- Check the resistance of the electrical equipment (See Sec 7.8).
- Check the crankcase for leaks and cracks.
- Clean engine if dirty or oily.
- Run up the engine.(See Sec. 5.3)

HKS 700E

6.2.2. 100-hour-inspection

- Carry out the 50-hour-check.
- Perform a compression check. (See Sec 7.3)

6.2.3. 200-hour-inspection

- Carry out the 100-hour inspection.
- Check the spark plug caps. Change if necessary.
- Change the spark plugs.
- Change the fuel filter.
- Change the air filter.

HKS 700E

6.3. Preservation of the engine for long term storage

For long out of operation periods and at extreme climatic conditions, we recommend the following instructions to protect against corrosion. Extra protection against corrosion beyond these recommendations is not necessary.

1. Warm up the engine, stop the engine, and empty the motor oil.
2. Fill up with new oil.
3. Drain the float chamber of the carburetors.
4. Apply oil to all pivots on the carburetors.
5. Close all openings, the exhaust tubes, the breather tube and air filters. Protect them against dirt and moisture.
6. Coat all the steel engine parts with engine oil.

Bringing the engine back to operation

1. Remove all the plugs and fasteners.



CAUTION!

For longer storage periods, the preservation procedures must be performed at least annually.

6.4. Winter operation

6.4.1. Care of the electrical system

Generally in the beginning of the winter an engine inspection shall be performed.

- Check all the connections of the ignition system and clean if necessary.
- Check the battery voltage.
- The battery poles and terminal connectors should be cleaned.

In countries with extremely low temperatures it is recommended to protect the battery against freezing by keeping it in a warm location for storage between flights. (See Sec 3.6)

HKS 700E

6.4.2. Cold starting procedures

Preheating the engine using hot air is recommended.

- Throttle OFF
- Choke ON

Limit cranking the engine to periods not much longer than 10 sec. After the engine starts, operate the choke as required to keep the engine running but avoid allowing the engine to exceed 2500 R/MIN.

6.4.3. Fuel system icing

(1) Icing due to water in the fuel

Water in the fuel will accumulate at the lower parts of the fuel system and can lead to freezing of the fuel lines, filters and carburetor jets.

Remedies:

- Use a fuel/water separating funnel, if the fuel supply is suspect.
- Drain the water in the fuel tank during the daily check.
- Drain and inspect the fuel system during the 50-hour inspection.
- Prevent fuel tank condensation, by keeping the fuel tank full when in short term storage, drain the fuel tank when not in use for longer periods.
- Avoid temperature differences between aircraft and fuel.

| |
|---|
|  CAUTION! |
|---|

| |
|--|
| Fuels containing alcohol always carry a small amount of water in solution. Temperature changes or an increase of alcohol content may cause water or a mixture of alcohol and water to settle to the bottom of the fuel tank and could cause engine stoppage. |
|--|

(2) Carburetor icing because of high air humidity.

With ambient temperatures between 32 Deg. F. (0 Deg. C) and + 60 Deg. F. (10 Deg. C) and very high humidity, carburetor icing may occur.

| |
|---|
|  WARNING! |
|---|

| |
|--|
| Under such atmospheric conditions monitor R/MIN. Engine stoppage may occur if operations are continued under these conditions. |
|--|

An electrical carburetor heating system is available as an option parts. Please see the parts list or the installation manual.

HKS 700E

7. MAINTENANCE

7.1. Changing the engine oil

- Warm the engine up to normal operational temperatures.
- Remove the oil drain screws from the engine and oil tank, drain oil, and replace the oil filter.
- Drain the oil from the oil cooler and oil lines.
- Screw in the oil drain screws. Tighten according Chapter 9.
- Fill with new oil in the oil tank (3L).
- Run engine at idle for 3 minutes.
- Recheck oil level of oil tank and fill if necessary, the oil level should be between 1/2 and 2/3rd of the oil tank.



CAUTION!

- (1) Use only multi-grade, brand name oils for automobile engines.
(Oil type See Sec. 3.6)
- (2) Don't use any aircraft engine oils and/or additives.

7.2. Air filter

For operation in heavy dust conditions, clean the air filter at shorter intervals or replace.

7.3. Compression test

Measure the engine compression using a compression gauge with a recording dial. The readings are taken with a fully open throttle at an engine oil temperature of between 86 Deg. F. (30 Deg. C) to 160 Deg. F. (70 Deg.C). If the readings are below 116 psi. (8 bar), A tear down to inspect the pistons, cylinders, valves and cylinder heads is required.

HKS 700E

7.4. Carburetor adjustments.

NOTE! The combustion condition of both cylinders is very important to achieve a smooth running engine. Carburetor adjustments are a flight critical operation; if you do not have experience in this operation, please get qualified assistance.

7.4.1. Idle speed adjustment

- For the first adjustment, turn back the stop screw so that the throttle valves close completely.
- Attach the vacuum gauges on both carburetors.

NOTE! The nipple for the vacuum gauge is attached at the side of the float chamber. Remove the screw and attach the vacuum gauge tube.

- Open the idle mixture screw approx. 1-1/2 turn.
- Warm the engine up.
- Keep throttle lever OFF.
- Keep 1400 r/min, adjusting both idle stop screws so that the vacuum readings are same.
- Confirm smooth running at idling.

7.4.2. Throttle cable adjustment

NOTE! This adjustment is very important. Both throttle valves must start to open at the same time.

- After idle adjustment, let the engine run at 2000 r/min.
- Check both vacuum readings.
- Adjust the throttle valve position by turning the outer-tube adjustment nut so that vacuum readings are same.
- Tighten the lock nuts.
- Remove the vacuum gauges.



DANGER!

The rotating propeller is extremely dangerous! Adjustments must be done with the utmost caution from behind the engine. The aircraft must be tied down or properly chocked. Do not perform this operation without a safety observer.

HKS 700E

7.5. Spark plugs

- Unscrew the plugs only with a cold engine.
- Brush clean with a plastic bristle brush.
- Do not use a brass brush or a steel wire brush for cleaning.
- After 200 hours, replacement of the spark plugs is required.
- Spark plug to use: DENSO IK24C11
- Torque the spark plugs with a cold engine only. (See Chapter 9.)

The shade of the spark plugs can give you the following information:

- Light brown to white:
Spark plugs and carburetor adjustment is correct.
- Velvety black:
Electrode gap too wide or the mixture is too rich.
Reduced air intake (air filter dirty) the proper exhaust gas temperature of engine is not reached
- Oily:
The spark plug is not firing or worn cylinder and piston rings.
- Pearly or glazed:
Wrong type of spark plug or the Spark plug not torqued properly, the mixture is too lean or badly closing valves.

7.6. Exhaust system

- Visually check for any damage and or leaks.
- Check attach-flanges at exhaust parts on cylinder. Tighten the nuts if necessary.

7.7. Misc. bolts and nuts

- Check for tightness, re-torque if necessary (See chapter 9.)

HKS 700E

7.8. Resistance of electrical equipment

Check the resistance of the electrical equipment according to TABLE 1.

TABLE 1.

| EQUIPMENT | LOCATION OF MEASUREMENT | RESISTANCE | VARIATION |
|---------------------------|---|-------------------|------------------|
| AC Magnetic stator | White - White of 3 phase connector | 0.4ohms | + - 20% |
| Pulse detector | White - Red Brown - Green | 310 ohms | |
| Ignition coil | Orange - center core | 0.2 ohms | |
| High tension coil | | 4.9 K-ohms | |

HKS 700E

8. OVERHAULS

8.1. **Major inspections at TBO** is to be performed by the manufacturer or approved service centers only. For this purpose the engine is to be sent with its logbook to the manufacturer or the nearest approved service center. The recommended time between overhaul (TBO) is at present 500 hours of operation. An increase of TBO due to field experience will be published in the Service Bulletins of the manufacturer.

8.2. **Major repairs and major modifications** are also only to be performed by the manufacturer or by approved service centers, which are authorized by the manufacturer. In case of prop strikes or sudden stoppage, the engine must be disassembled and the crankshaft must be checked for cracks. This is considered a major repair and must be performed by the manufacturer or an approved service center. If stoppage of the engine is concealed when ordering a repair or major overhaul, the responsibility for the damage and subsequent costs still exists for the owner concealing the damage

9. TABLE FOR TORQUE VALUES

| | | ft. Lbs | Kgm |
|-----------------------|-----|------------|-----|
| Spark plug | M14 | 14.5 to 21 | 2-3 |
| Oil drain screw | M14 | 21 | 3 |
| Rear cover screw | M6 | 8.5 | 1.2 |
| Oil pump screw | M5 | 5.5 | 0.8 |
| Crankcase screw | M6 | 8.5 | 1.2 |
| | M8 | 17 | 2.4 |
| | M10 | 34.5 | 4.8 |
| Front cover screw | M6 | 8.5 | 1.2 |
| Gear cover screw | M6 | 8.5 | 1.2 |
| Cylinder screw | M6 | 8.5 | 1.2 |
| Head cover screw | M5 | 5.5 | 0.8 |
| Screw for starter | M6 | 8.5 | 1.2 |
| Intake manifold screw | M8 | 17 | 2.4 |
| Insulator | M8 | 17 | 2.4 |

HKS 700E

10. TROUBLE SHOOTING

10.1. Engine does not fire

| Cause | Action |
|---|--|
| Ignitions OFF | ON. |
| Spark plug gap too big | Change plugs or re-gap plugs. |
| Fuel shutoff valve OFF or fuel filter blocked | Fuel shutoff valve ON, clean or replace fuel filter. |
| Lack of fuel | Fill fuel tank. |
| Ignition line loose or damaged | Check line connections. Replace if necessary. |
| Battery defective or discharged | Install charged battery or recharge. |
| Starting speed too low, start problems | Check the oil grade. Use a top on cold engine quality, low friction oil. |
| Spark plugs wet from condensation | Dry plugs inside and outside. |
| Spark plugs wet with fuel (over-choked) | Dry spark plugs, follow up and overflow of carburetor. Correct trouble in the fuel system. |
| Float valve dirty or defective | Clean or replace valve. |
| Carburetor jets blocked | Remove and clean the jets |
| Water in carburetor | Clean and empty carburetor bowls, fuel lines and filter. |
| Insufficient compression | Check compression, a major overhaul may be needed. |
| Inner mechanical defect | Check the oil for metal parts. If contamination exists it may be necessary to overhaul the engine completely. |

HKS 700E

10.2. Warm engine shows irregular idling

| Cause | Action |
|-----------------------------------|---|
| Choke ON | Choke OFF. |
| Idle mixture incorrectly adjusted | Adjust carburetors according 7.4.1. |
| Float needle valve dirty, jammed | Clean float needle valve or replace it or worn out. |
| Intake manifold leaky | Tighten all connections of the intake. Replace any defective parts. |

10.3. Engine runs erratic or misfires occasionally

| Cause | Action |
|---------------------------|--|
| Spark plug failure | Clean plugs inside and outside. Replace if necessary. |
| Ignition wire breaks down | Check ignition wire and replace if necessary. |
| Ignition troubles | Check complete ignition system and replace parts if necessary. |
| Fuel filter blocked | Disassemble and clean, or replace the filter. |

10.4. Engine overheats, Oil temperature over 212 Deg. F. (100 Deg. C)

| Cause | Action |
|---|---|
| Fuel-air mixture too lean | Check adjustment and operation of carburetor and correct if necessary. |
| Too much oil remaining in the crankcase | Check the oil return line. |
| Insufficient air-flow to the oil cooler | Check and clear the air passages. |
| Insufficient oil supply | Check oil level and fill if necessary. |
| Poor oil quality | Change oil. Use prescribed oil grade. |
| Oil filter blocked | Change the filter. |
| Defective oil temperature gauge | Replace the gauge. |
| Excessive piston blow by | Major overhaul is necessary. |
| Bearings defective | If there is metal contamination in the crankcase sump, a major overhaul is necessary. |

HKS 700E

10.5. The engine does not develop full power

| Cause | Action |
|---|--|
| Ignition trouble | Tighten all connections. |
| Too much oil remaining in the crankcase | Check oil return line. |
| Fuel supply inadequate | Check fuel filter. |
| Incorrect fuel grade | Refuel with prescribed grade fuel. |
| Throttle lever incorrectly adjusted | Adjust the throttle cables to allow full range on carburetors. |
| Intake leaking | Tighten all connections. Replace defective parts. |
| Carburetor diaphragm damaged | Replace carburetor diaphragm. |

10.6. Low oil pressure

| Cause | Action |
|---|--|
| Insufficient oil in oil tank | Check oil level and fill if necessary. |
| Oil remains in engine and doesn't circulate | Check oil return line to tank. |
| High oil temperature | See 10.4. |
| Pressure loss | Check the pressure control valve. |
| Air in suction line | Vent the oil line. |
| Defective oil pressure gauge | Replace the oil pressure gauge. |
| Bearings defective (no oil pressure) | A major overhaul is necessary. |

10.7. The engine does not stop immediately

| Cause | Action |
|---------------------------|--|
| Idle speed too high | Adjust proper idle speed (1400 R/MIN). |
| Ignition switch defective | Replace the switch. |
| Engine overheated | Cool down engine with about 2000r/min. |

HKS 700E

10.8. Excessive oil consumption

| Cause | Action |
|--|---|
| Piston rings or oil scraper rings worn | A major overhaul is necessary. |
| Poor oil quality | Change oil. Use correct oil grade. |
| Worn valve guides or bad valve guide seals | A top overhaul is necessary. |
| External oil system leaky | Check for defects and correct as necessary. |

10.9. Engine "knocks"

| Cause | Action |
|--|---------------------------------------|
| Using fuel with a low octane rating | Use fuel with a higher octane rating. |
| Spark plug fitted without sealing washer | Use one sealing washer on each plug. |
| Residue in combustion chamber | Inspect and remove residue. |

10.10. Engine hard to start at low temperatures

| Cause | Action |
|------------------------|---|
| Starting speed too low | Preheat the engine. |
| Low battery charge | Replace battery or recharge. |
| High oil pressure | During a cold start a pressure reading of up to 100 psi (7 bar) doesn't indicate a malfunction. |

HKS 700E

11. INSPECTION AND MAINTENANCE ITEMS

| HKS-700E Inspection and maintenance program | | | | |
|--|---------------------------|-------------|--------------|--------------|
| Inspection-maintenance item. | Hourly inspection routine | | | |
| | First 25hr. | Every 50hr. | Every 100hr. | Every 200hr. |
| 1. Check condition of throttle cable, starting carb. | ○ | ○ | ○ | ○ |
| 2. Engine mounts-check for cracks, looseness of mounts, and looseness of engine to mount. | ○ | ○ | ○ | ○ |
| 3. Check for looseness of bolts, nuts and pins. | ○ | ○ | ○ | ○ |
| 4. Check for oil leaks from hose, tank and fittings. | ○ | ○ | ○ | ○ |
| 5. Exchange oil filter. | ○ | ○ | ○ | ○ |
| 6. Perform oil change. | ○ | ○ | ○ | ○ |
| 7. Check the magnet of oil drain screw for the metal contamination. | ○ | ○ | ○ | ○ |
| 8. Fuel lines-check for leaks, safeties and wear. | ○ | ○ | ○ | ○ |
| 9. Fuel filter-check, clean or replace. | ○ | ○ | ○ | ○ |
| 10. Check ignition harness for damage and tight connections at spark plug cap. | ○ | ○ | ○ | ○ |
| 11. Air filter-check, clean or replace. | ○ | ○ | ○ | ○ |
| 12. Check mounting of carburetors, and the insulator rubber for cracks. | ○ | ○ | ○ | ○ |
| 13. General condition of the exhaust system, Check muffler and attaching flanges at exhaust port on cylinder for leakage. | ○ | ○ | ○ | ○ |
| 14. Check ignition coils for wear and security of attachment. | ○ | ○ | ○ | ○ |
| 15. Check for leaks at oil pressure and temperature sensor. | ○ | ○ | ○ | ○ |
| 16. Electrical wiring-check for damage, wear and security of attachment. | ○ | ○ | ○ | ○ |
| 17. Check resistance of electrical equipment. | ○ | ○ | ○ | ○ |
| 18. Check crankcase for leaks and cracks. | ○ | ○ | ○ | ○ |
| 19. Clean engine if dirty or oily. | ○ | ○ | ○ | ○ |
| 20. Compression check (See operation manual). | | | ○ | ○ |
| 21. Check spark plug caps. Change if necessary. | | | | ○ |
| 22. Change spark plugs. | | | | ○ |
| 23. Change the fuel filter. | | | | ○ |
| 24. Change the air filter. | | | | ○ |
| 100-hr-inspections must be performed at least annually. The overhaul must be performed within 5 years after shipping or 500hours operation time. | | | | |

HKS 700E

WARRANTEE CONDITIONS

The HKS non-certified aircraft engines limited warranties

1) Period

HKS as manufacturer, warrants through their authorized HKS distributors from the date of sale to the first consumer, every HKS non-certified engines, sold as NEW and UNUSED, and delivered by an authorized HKS distributor for a period of the earliest of:

- 6 consecutive months for private use owners**
- or 12 consecutive months from date of shipment of the HKS distributors**
- or the first 100 operation hours**

2) What an authorized HKS distributor will do

The authorized HKS distributor will, at its option, repair and/or replace components defective in material and/or workman ship under normal use and service, with a genuine HKS component without charge for parts or labour, during said warrantee period. All parts replaced under warrantee become the property of HKS.

3) Condition to have warrantee work performed

You must present to an authorized HKS service-center, the hard copy of the HKS warrantee registration card and/or proof of purchase delivered to the customer from the selling dealer at time of purchase.

4) Exclusion - are not warranted

- Normal wear on all items.
- Replacement parts and/or accessories that are not genuine HKS parts and/or accessories.
- Damage resulting from the installation of parts other than genuine HKS parts.
- Damage caused by failure to provide proper maintenance as detailed in the OPERATIONS MANUAL. The labour, parts and lubricants costs of all maintenance services, including tune-ups and adjustments will be charged to the owner.
- Aircraft engines designed and/or used for racing or commercial purposes.
- All optional accessories installed on the aircraft engine (The normal warrantee policy for parts and accessories, if any, applies).
- Damage resulting from running the aircraft engine without propeller.
- Damage resulting from modification to the aircraft engine not approved in writing by HKS.

HKS 700E

- Damage caused by electrolysis.
- Cold seizure and piston scuffing.
- Use of a gear reduction not designed by HKS.
- Use of propellers, which exceed the inertia and balance limits as specified by HKS.
- If engine instruments recommended by HKS have not been installed.
- Losses incurred by the aircraft engine owner other than the parts and labour, such as, but not limited to, mounting and dismounting of the engine from the aircraft, loss of use, transportation, towing, telephone calls, taxis, or any other incidental or consequential damage.
- Damage resulting from accident, fire or other casualty, misuse, abuse or neglect.
- Damage/rust/corrosion premature wear to the engine caused by water ingestion.
- Damage resulting from sand/stones infiltration.
- Damage resulting from any foreign material ingestion.
- Damage resulting from service by an unqualified mechanic.

5) Expressed or implied warranties

This warranty gives you specific rights, and you may also have other legal rights which may vary from state to state, or province to province. Where applicable this warranty is expressly in lieu of all other expressed or implied warranties of HKS, its distributors and the selling distributor, including any warranty of merchantability or fitness for any particular purpose; otherwise the implied warranty is limited to the duration of this warranty. However, some states or provinces do not allow limitations on how long an implied warranty lasts, so the above limitation may not apply.

Neither the distributor, nor any other person has been authorized to make any affirmation, representation or warranty other than those contained in this warranty, and if made, such affirmation, representation or warranty shall not be enforceable against HKS or any other person.

HKS reserves the right to modify its warranty policy at any time, being understood that such modification will not alter the warranty conditions applicable to aircraft engines sold while the above warranty is in effect.

HKS 700E

6) Consumer assistance procedure

If a servicing problem or other difficulty occurs, please contact: -authorized HKS service-center or authorized HKS distributor.

7) Warrantee will only be valid if the end user completes this registration card as soon as the aircraft engine goes into service, and returns it to the national authorized HKS distributor of the area in which the aircraft engine is firstly operated.

8) This warrantee will be effective for all non-certified aircraft engines delivered by HKS as of September 1st, 1997.

9) WARNING!

This is a **non-certified** aircraft engine, the possibility of engine failure exists at all times. Do not operate this engine over densely populated areas. Do not operate this engine over terrain where a safe, power off landing cannot be performed.

The operating and maintenance instructions supplied with this engine must be followed at all times. Flying any aircraft involves the risk of injury or death, building and maintaining your own aircraft requires great **personal responsibility**.

HKS 700E

WARRANTEE CARD

WARRANTEE / OWNER'S REGISTRATION CARD



1. To be eligible for warrantee, this registration card must be returned completed and signed by the end user to the authorized HKS distribution partner of the area of the permanent residence of the end user and/or in which this non-certified aircraft engine is firstly operated, within 30 days as of date of purchase.

2. No other warrantees and/or guarantees than defined in the actual warrantee conditions are made.

3.

Engine type: HKS700E

Engine S/N.:

Date of purchase:

Buyer:

Address:

Telephone:

Seller:

I have read and understood the operations manual in its entirety.

Date:

Signature: