

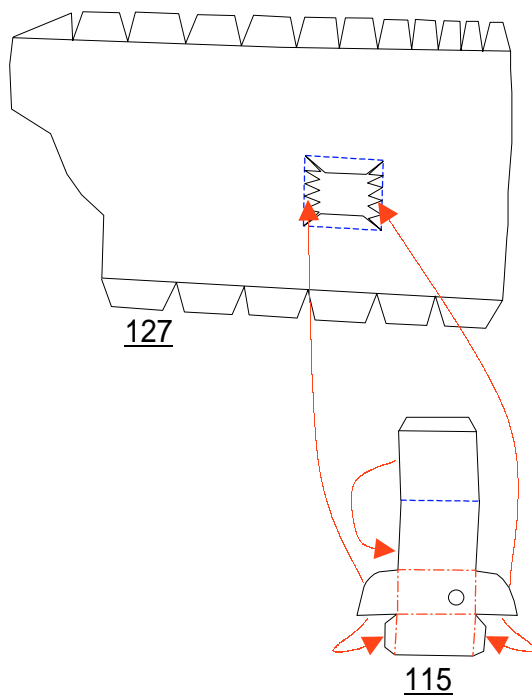

3. 車輪を付けるときに組み立てます。車輪を付けないときは不要です。  
107と～128の部品も同様に組み立てます。

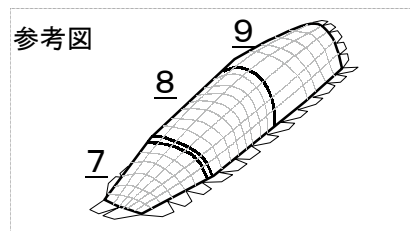

4. 下の参考図の様にカーブを付けて接着します。

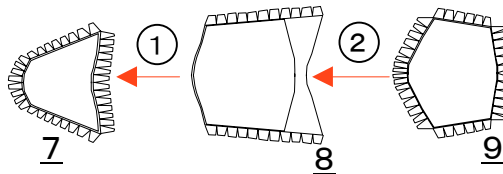

5. 各部分を曲げた後参考図のように13の裏側に14を接着します。

11、12も同様に組み立てます

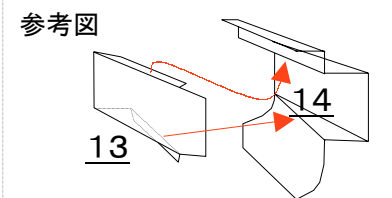
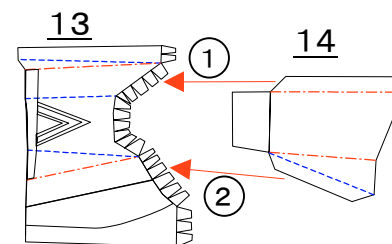

6. 各丸くカーブ御付けて接着します。  
22は図1のように途中に接着し22と24を接着します  
21、23も同様に組み立てます。

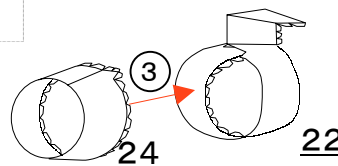
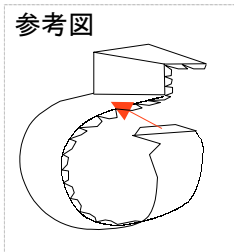
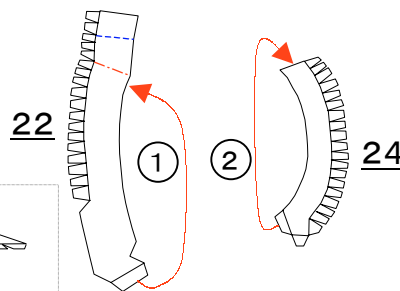

7. 各部分を折り曲げたあと接着します。

狭い部分などは定規を当てて曲げるか  
又は、先のとがったもので曲げる線を  
軽くなどってから曲げましょう。

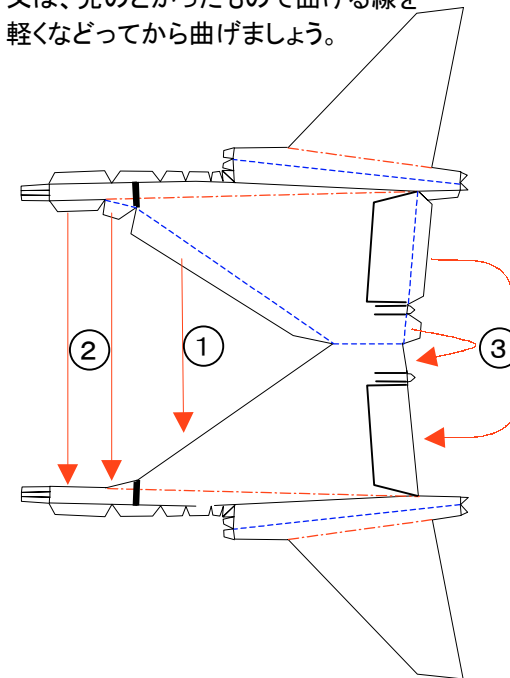

8. 前部分を組み立てます。

車輪を付けるときは5, 6, 10の部品は124, 125, 126に  
15, 16の部品は3. で作った部品に代えて作ります。

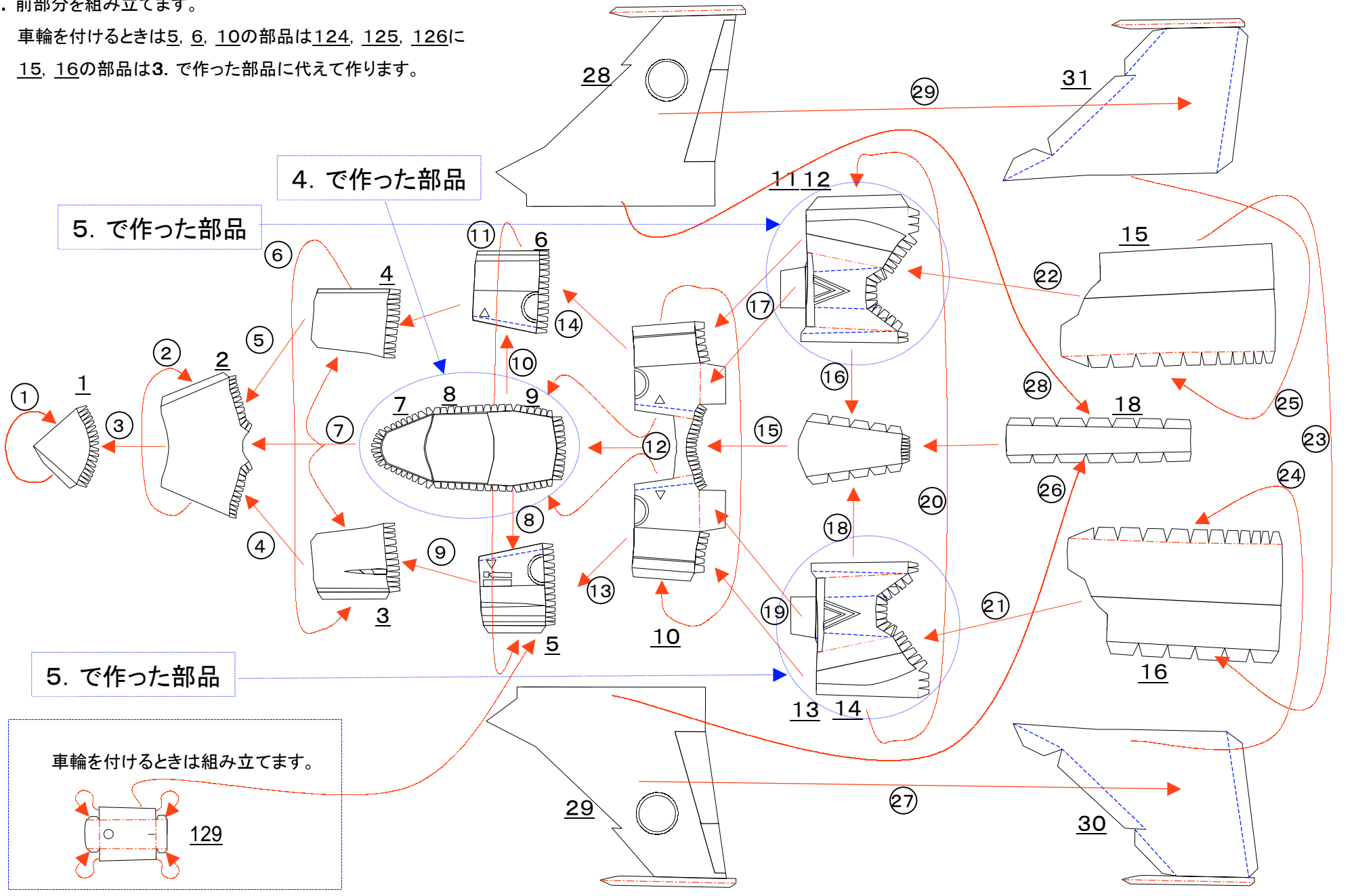

9. 後部分を組み立てます。

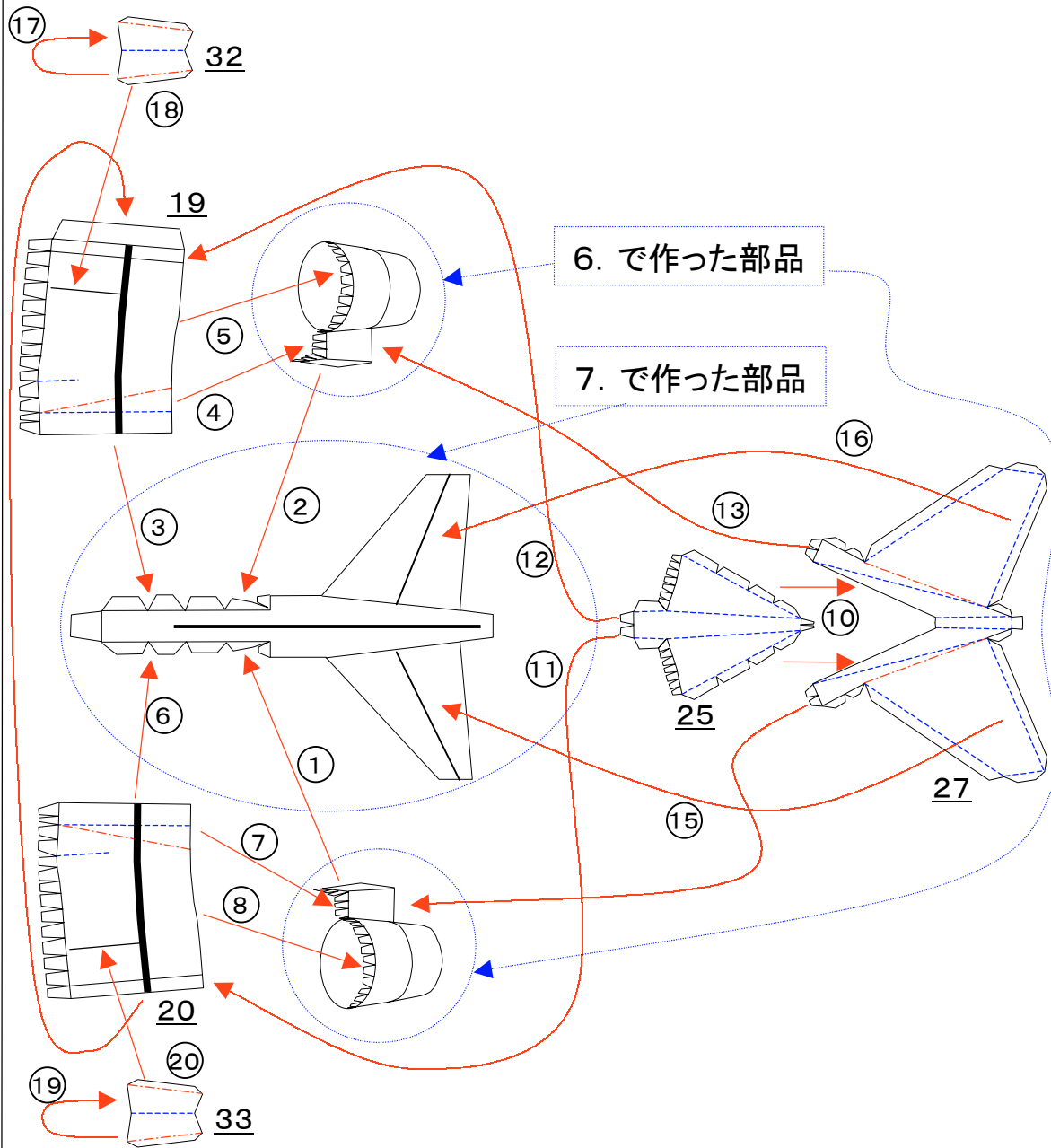

10. 前と後ろを組み立てて車輪つけて出来上がり。

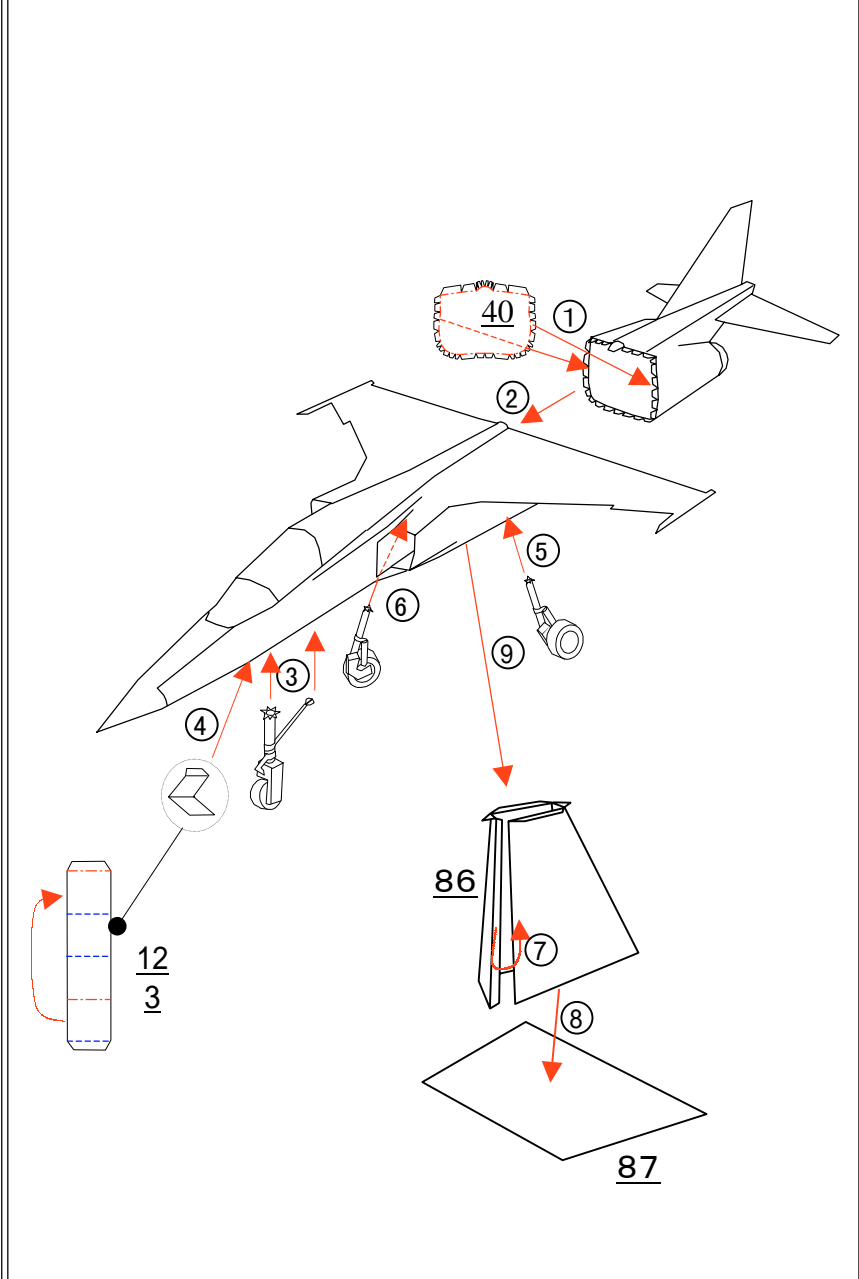

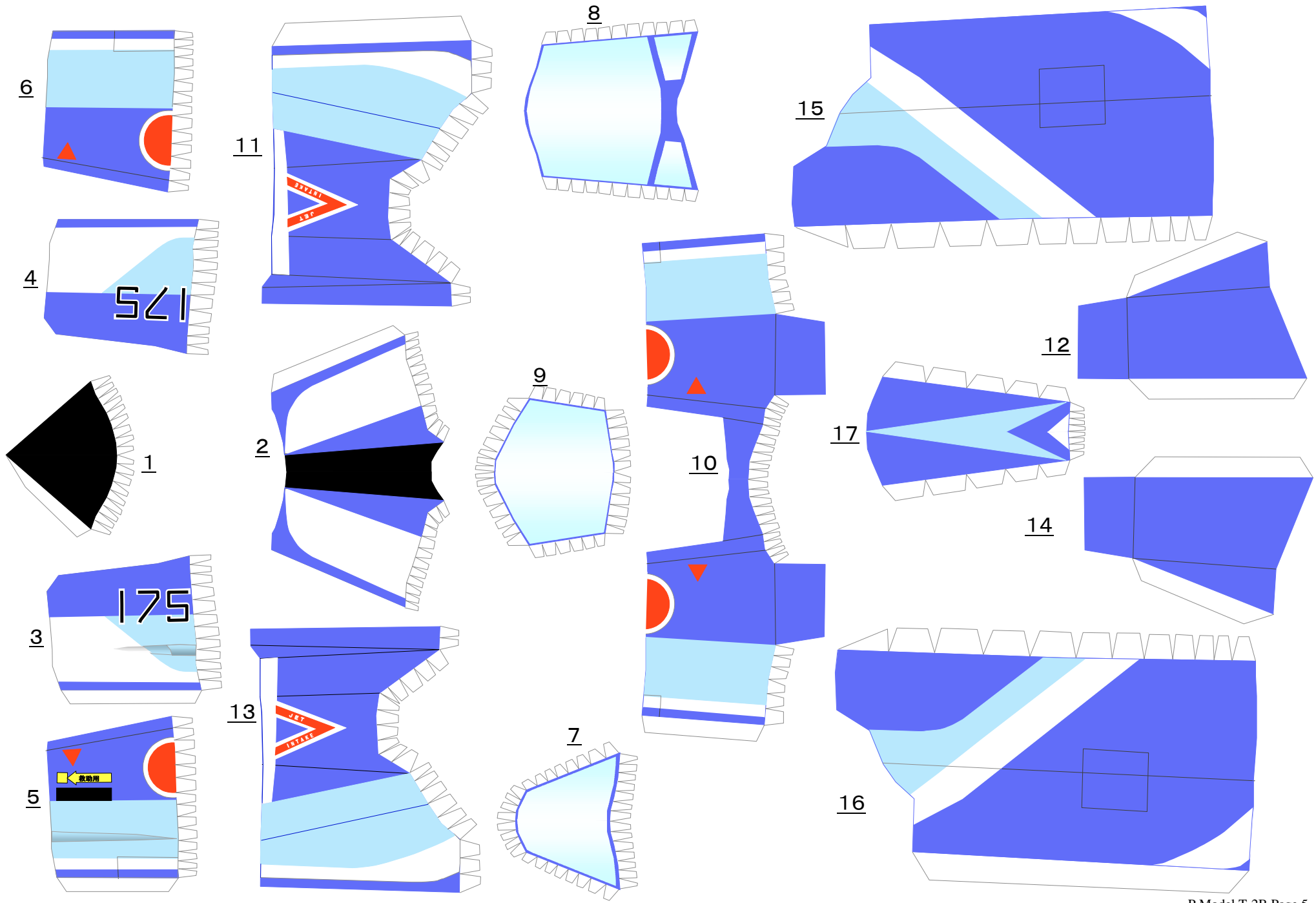

19

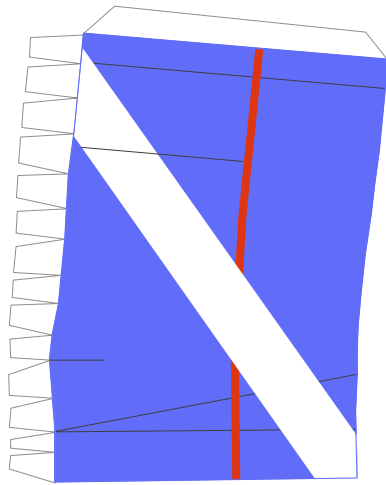

18

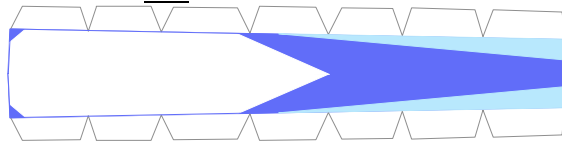

20

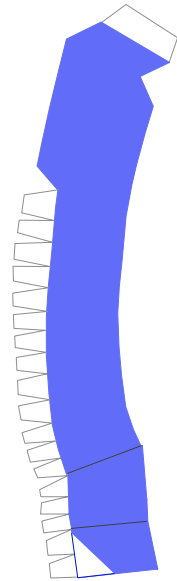
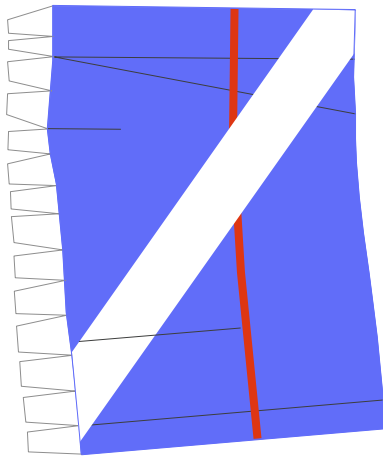

21

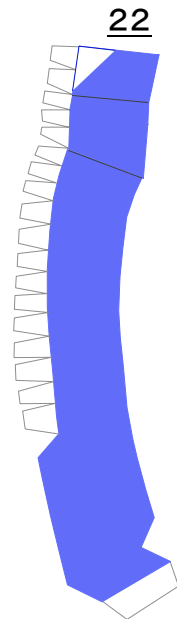

22

23

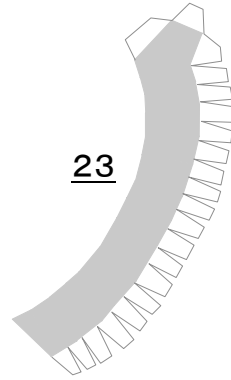

25

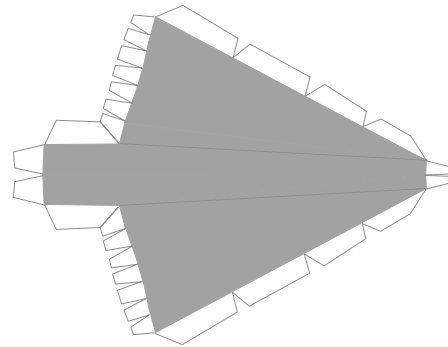

24

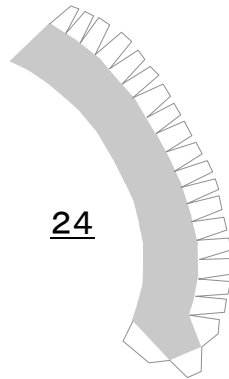

32

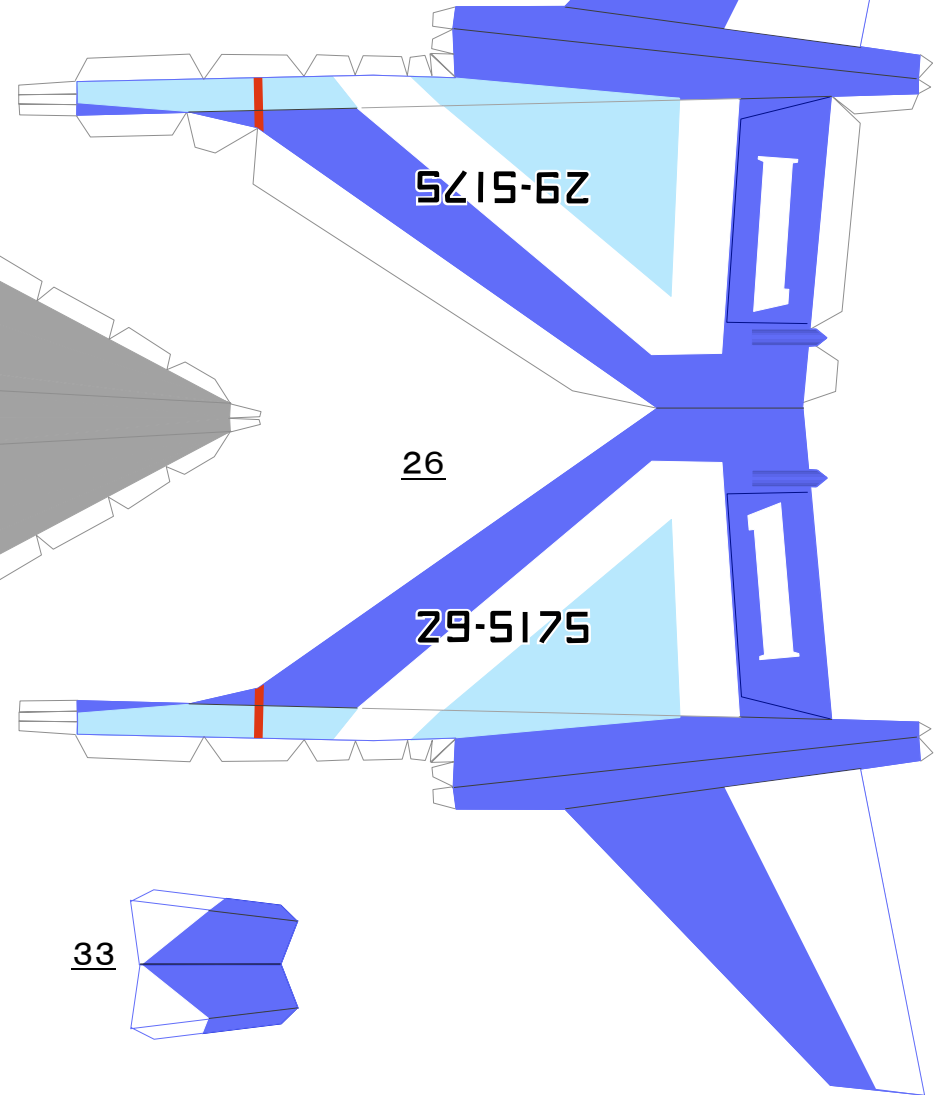
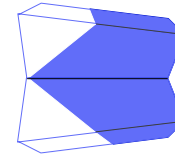

**29-5175**

**26**

**29-5175**

33

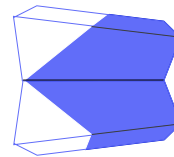

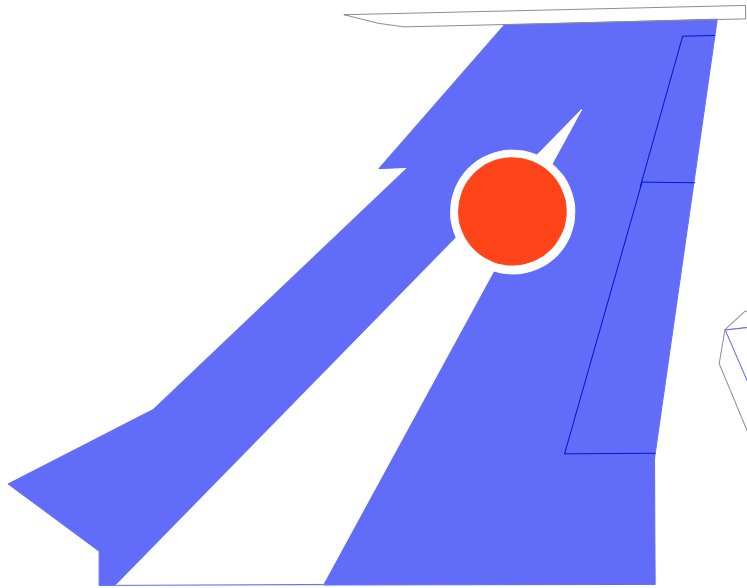

28

29

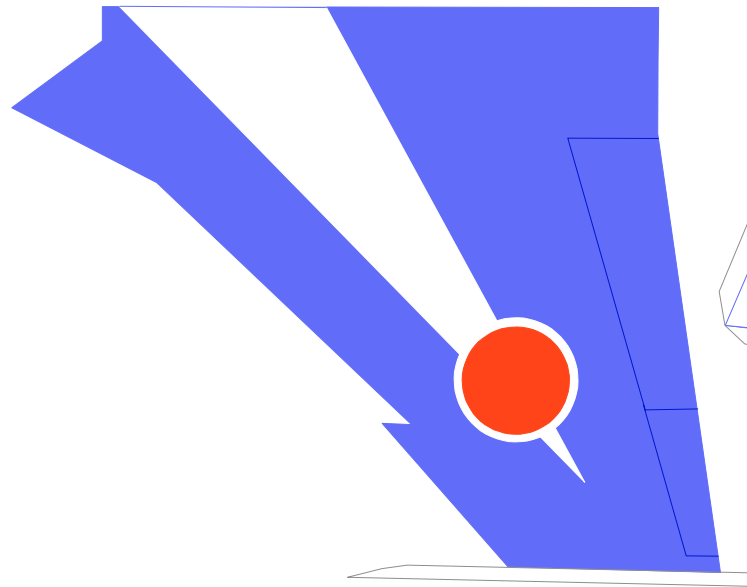

37

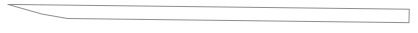

36

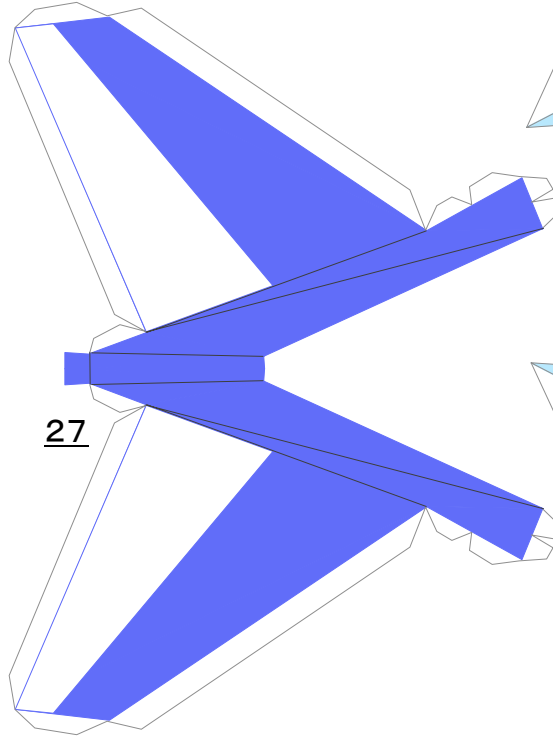

27

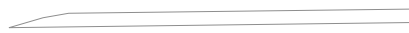

34



35

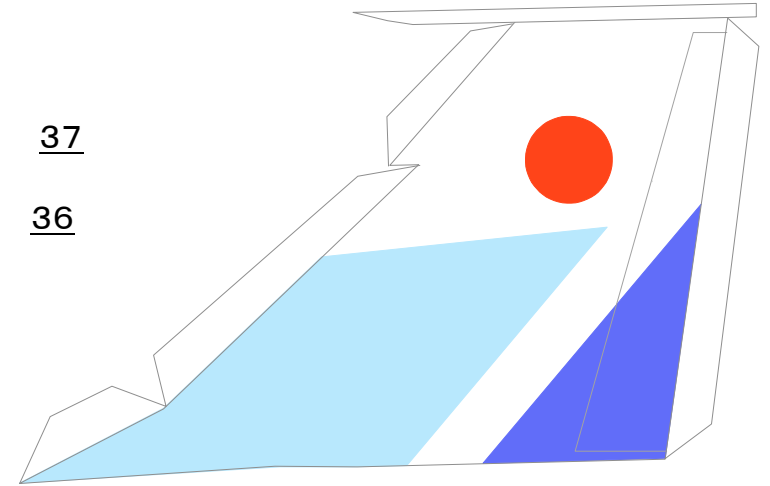

30

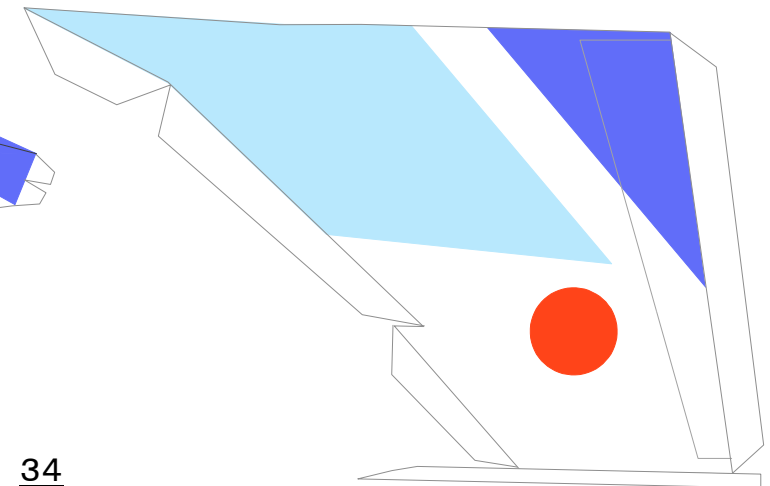

31

