

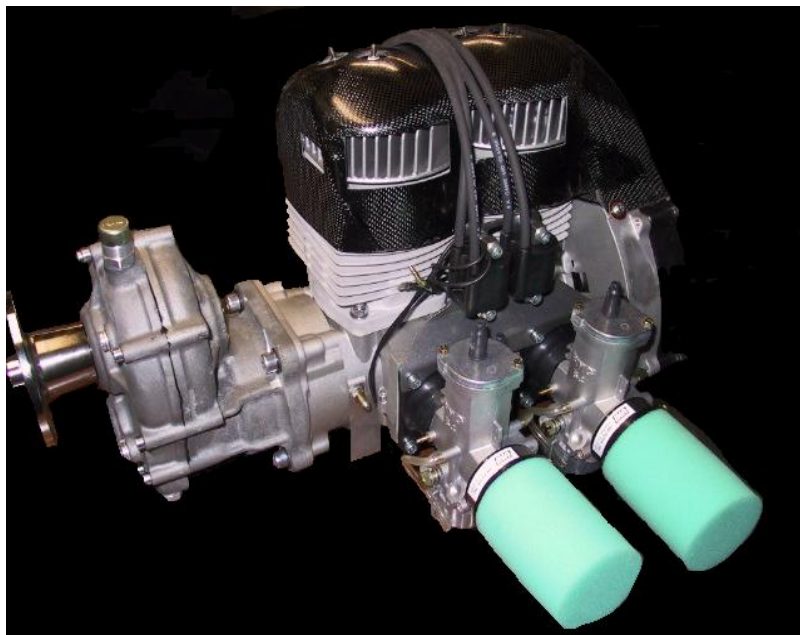

## **INSTRUCTION AND MAINTENANCE MANUAL**



# MZ 202

**We recommend reading this manual before installing or using the engine**

Compact Radial Engines Inc.  
#3-8473 124<sup>th</sup> Street  
Surrey, B.C.  
Canada. V3W-9G4

<b>CONTENTS</b>	<b>PAGE</b>
Warning	3
Introduction	4
Engine delivery	5
Warranty	5
Important safety tips	6
Technical specifications	7
Performance Diagram	8
Main torque settings	8
Oil and Fuel	9
How to prepare your fuel/oil Mixture	10
Pre-Start Procedures	10
Starting up the engine for the first time	11
Step One Break –In	11
Final check	12
Start up procedure	12
Adjusting the carburetor	13
The Gear Drive	14
Trouble-shooting	15
Wiring diagram	18
Maintenance schedule	19
List of spare parts	22
Preliminary flight inspection	23
Engine repairs logbook	24
Exploded view of the MZ202	25

Modifications or different mountings Compared to original model	Date

# WARNING

## **This is not an aeronautic approved engine.**

This engine has not been subjected to durability and safety tests in compliance with aeronautical standards and is not a certified engine. It is designed to be used in ULM or aeroplanes where engine failure will not produce serious consequences.

The user must assume responsibility for all risks deriving from the use of this engine and must understand that this engine is subject to sudden failure.

Engine failure may result in an emergency landing. Such accidents may cause serious material damage, injury and/or death.

Never use an aircraft fitted with this engine in areas, conditions and altitudes that may cause problems if forced to land as a result of sudden engine failure.

## **INTRODUCTION**

Congratulations on having chosen the MZ202 engine. The special design of the various components makes this a particularly lightweight, sturdy and reliable model. If it is **installed correctly and serviced regularly**, your engine will last for a long time and meet your requirements in full.

Avant-garde technology was employed to manufacture this engine which is unique in its kind. The light alloy cylinder has been treated with Nikasil and is lightweight, reliable and has a virtually endless life span. The crankshaft is made of nickel-chrome-molybdenum steel hardened, ground and built to high standards of resistance.

Computer Numerical Control (C.N.C.) equipment and CAD-CAM technology have made it possible to build ultra-light crankcase. Furthermore, the crankcase incorporates the electric starter motor.

A 13.8 volt, 180-Watt alternator serves the ignition system and is used to re-charge the starter battery. Electronic double ignition switching type with variable automatic timing guarantee reliability, safety and optimum engine performance.

The above features ensure the MZ202 is a complete, lightweight and reliable propulsion system. Like all high-performance engines, the MZ202 **demands care and maintenance**. It is vitally important to use suitable fuel and a good blend of synthetic oil for two-stroke engines with a 50:1 ratio. **Proper servicing and an appropriate use are essential requisites.**

This manual aims to explain as clearly as possible how to install and get the best out of your engine.

## **ENGINE DELIVERY**

Upon delivery of the MZ202, check that the components were not damaged during transportation. Free the engine from any pieces of packing material, which may still be trapped between the cylinder head cooling fins or cylinder; check that the exhaust manifold and carburetor are not obstructed.

## **WARRANTY**

### **Warranty period:**

The warranty is valid for a period of six consecutive months from the date the ORIGINAL CONSUMER purchased the engine from an **authorised distributor** and/or **authorised service centre**. Please retain your receipt, as it will serve as the date for proof of purchase.

### **Conditions:**

The warranty will only be in effect when the purchase was made through an authorised distributor issued by Manufacturer C.R.E. Inc. The manufacturer reserves the right to modify dimensions and materials without prior warning. The warranty covers faulty components or manufacturing defects.

### **The following item or conditions are not covered under warranty**

- The normal wear and tear of components.
- Seizure and Piston scuffing
- The electric starter motor
- Damage produced by transporting the engine, accidents, fire, improper use, negligence
- Damage produced by premature wear or corrosion as a result of the engine being immersed in water or other causes.
- Replacement parts and/or accessories that are not genuine MZ parts and/or accessories
- Damage resulting from the installation of parts other than genuine MZ parts
- Damage caused by failure to provide proper maintenance as detailed in the Operator's Manual. The labour, parts and lubricants costs of all maintenance services, including tune-ups and adjustments will be charged to the owner
- Engines designed and/or used for racing or commercial purposes
- All optional accessories installed on the aircraft engine. (the normal warranty policy for parts and accessories, if any, applies)
- Damage resulting from running the engine without a propeller
- 
- **non warranty continued:**
- Damage resulting from modification to the engine not approved in writing by C.R.E. Inc.
- Use of a gearbox not designed by C.R.E. Inc.
- Use of propellers which exceed the inertia and balance limits as specified by C.R.E. Inc.
- If engine instruments have been installed not approved by C.R.E. Inc.
- Damage resulting from any foreign material ingestion
- Damage resulting from service by an unqualified mechanic

## **IMPORTANT SAFETY TIPS**

Safety is everybody's concern. We set out here below an incomplete list of safety precautions to be taken when using the MZ202. It would be impossible to list all the circumstances, which may occur when you use this engine, but by being aware of the potential dangers, you will also reduce some of the risks involved with the use of this engine.

### **Nonetheless, here is some useful advice**

- Never mix fuel in a closed environment where the vapours could cause an explosion.
- Ensure all the engine controls are fully functioning and that you are able to locate the **START-STOP** switch. Make sure you can activate all the controls easily and that you can therefore use them instinctively and without hesitation.
- Never re-fuel if there is a chance of the fuel dripping onto the hot engine. Use only approved containers and ensure you comply with the relevant safety regulations when transporting fuel.
- Before each use, check the engine's mounting points, propulsion components, fuel lines, wiring and fuel and air filters.
- Use only a clean fuel/oil mixture immediately before using the engine. Check the intake and exhaust ports. When not in use, protect the engine to prevent impurities from entering the fuel lines or the fuel itself. **Ensure everything is correctly done before starting the engine.**
- The engine must be always serviced regularly in order to foresee engine failure at all times.
- Never run the engine on the ground when the propeller is rotating unless the aircraft is located in an area where you can check that nothing and no-one can access the danger zone.
- Never abandon your aircraft with the engine running.
- If the engine behaves unpredictably, keep a written record. In the event of any problems, do not take to the air before solving the problem and make a record in the engine logbook.

## TECHNICAL SPECIFICATIONS

Model	MZ202
Type	two-stroke, double-cylinder in line, lamellar engine
Cooling system	air cooling system, by means of forced air (fan)
Direction of rotation	anti-clockwise seen from the PTO
Capacity	626cc (Nikasil cylinder)
Bore x stroke	76 mm x 69 mm
Compression ratio	9.1 / 1
Power output	63 hp at 6250 rpm
Peak torque	84 Nm at 5200 rpm
Lubrication	Fuel / oil blend 50 : 1 synthetic oil Castrol TTS
Fuel type	Super 95 RON / MON 85
Ignition	Magneto flywheel with electronic transducer with variable timing. Electric regulator and battery charger output: 180W 13.8 Volt
Carburetor	2 x Bing 54 with float chamber and fuel pump.
Spark plug	NGK C8HS spark gap 0.7 mm (0.027")
Operating temperature	CHT max. 260° C (500°F) EGT max . 680°C (1250 °F)
Starting	By 450 W electric starter motor
<b><u>Weight</u></b> GMP	38 kg engine complete with starter motor, carburetors, fuel pump, cooling system, exhaust system.

## MZ202 FREE AIR PERFORMANCE DIAGRAM

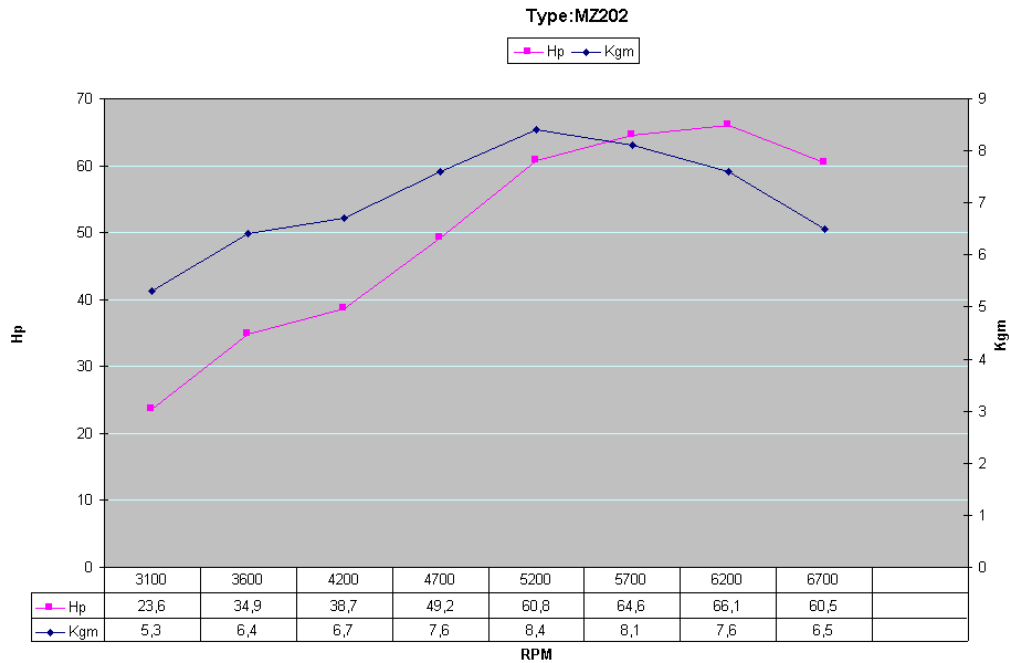

## MAIN TORQUE SETTINGS

Name		Nm
Cylinder head screws	M6	13 + 2
Crankcase screws	M6	16 + 2
Magneto flywheel nut	M10 x 1	70 + 3
Cylinder nuts	M8	23 + 2
Pump suction pressure takeoff	M6 x 1	6 + 2
Spark plug	M10 x 1.5	20 + 2
Wooden Prop fastening screw	M8	15 + 2
Other screws or nuts	M8	20 + 2
Other screws or nuts	M6	10 + 2
Fan case	M6	10+2
Fan nut	M6	15+3



## **OIL AND FUEL**

Whichever brand of oil and fuel you use, please read the following which will help you keep the engine in perfect running order.

- The presence of impurities in the fuel is the main cause of engine failure. To prevent the fuel from being contaminated, it is necessary to take care from the beginning, because the potential risk increases if impurities enter the fuel tank. Always use a clean fuel container that complies with safety standards. Always filter the fuel when you fill or change the container. Do not fill the container to the brim; never forget that fuel may increase in volume.
- Do not use fuel/oil mixtures which have been stored for a long time or which have been exposed to sunlight in a translucent container. Mix the fuel and oil thoroughly before filling the fuel tank because there is a risk of the two liquids separating in time.
- Choose the same type and brand of oil and stick to it unless it causes problems. By doing so, you will get to know the product well and you will be able to assess whether it suits your engine. If you change the type of oil frequently and your engine has problems, you will never know which type of oil is responsible for any problems you may have.
- It is extremely important to avoid switching from a synthetic oil to a mineral based oil. The two types are not always compatible and, if mixed, it is possible that a film may form and obstruct the engine's components or cause other problems. As a rule of thumb, 20% of cases where the user has switched from a synthetic oil to a mineral based oil has resulted in problems with the engine.
- If the engine has been installed inverted (with the spark plug pointing downwards), choose an oil that leaves few carbon deposits. Oil deposits tend to build up in the lowest parts, for example, in the spark plug cavity. If these deposits do not burn during normal use, the spark plug is fouled and this may result in self-ignition. Manufacturers of top brand lubricants guarantee the quality of their products.

Oil specifications: **synthetic oil for two-stroke engines: 50 : 1 ratio (Castrol TTS recommended)**

Fuel specifications: the octane rating should be minimum: R.O.N.93 or more.

## **How to prepare your Fuel/Oil Mixture**

A good method for preparing the fuel/oil mixture could prevent a good deal of problems. By adopting the same method every time, the preparation will become an automatic process that will simplify matters.

Always use a clean approved container: make sure it is also free of condensation and that you know the exact capacity.

1. To dilute the oil more easily, pour a small amount of fuel into the container.
2. Pour in the required amount of oil. Shake slowly to mix the oil and fuel.
3. Add sufficient fuel to obtain the prescribed fuel/oil mixture. If you use a filter at this stage, it should have a very fine mesh in order to filter any water or foreign particles.
4. Screw the lid back onto the container and shake vigorously. Pour the fuel/oil mixture into the fuel tank of your aircraft. Use a funnel with a filter that is fine enough to prevent any impurities from entering the fuel tank whilst allowing the oil to pass through.

## **PRE-START PROCEDURES**

**Before starting up the engine for the first time, carry out a general inspection, checking in particular:**

- The carburetor and fuel feed circuit are securely installed.
- Check the vacuum pressure tubing between the crankcase inlet and fuel pump, if you have a Bing carburetor, or the base of the carburetor if you have a Tillotson model.
- Check the condition of the electric cables and that the spark plug's high tension lead has been fitted correctly.
- Check that the two black cables going from the engine shut-off control to the switch have been connected correctly
- Ensure the rubber engine mounts are properly installed and that the locking bolts have been tightened sufficiently.
- Check the gear box and all bolts, nuts on the gear box.
- Never run the engine without the propeller; this is particularly important for the free air model.
- Ensure the propeller and locking bolts are in good condition. Check that the propeller is suitable for the engine as well as the direction of rotation is correct.

**STARTING UP ENGINE for the FIRST TIME AND BREAK-IN**

The engine must be installed and a properly loaded, which means a propeller of the correct rotation matched for max engine RPM. Also insure that the airplane is properly anchor or tied to a strong a suitable anchor which will allow full engine run-up.

**There are two steps which have to be followed to insure proper engine break-in occurs.** However during both steps insure that the temperature of the cylinder head never exceeds **260°C or 500 F**. If during the break-in procedure you feel you are going to exceed the max cylinder head temperature as per above, interrupt the run, cool down engine at idle for a minimum of 1 minute and continue where you interrupted the run. During the break-in procedure, it is particularly dangerous to increase the ratio of the fuel/oil mixture. An excessive amount of oil will cancel the benefits of the break-in procedure of this engine.

**STEP ONE**

Step one is a preliminary engine run-up to insure that the engine is installed correctly and that all systems are working correctly. After completing Step one insure all hoses are not leaking and cables are fastened securely.(All time lengths are minutes).

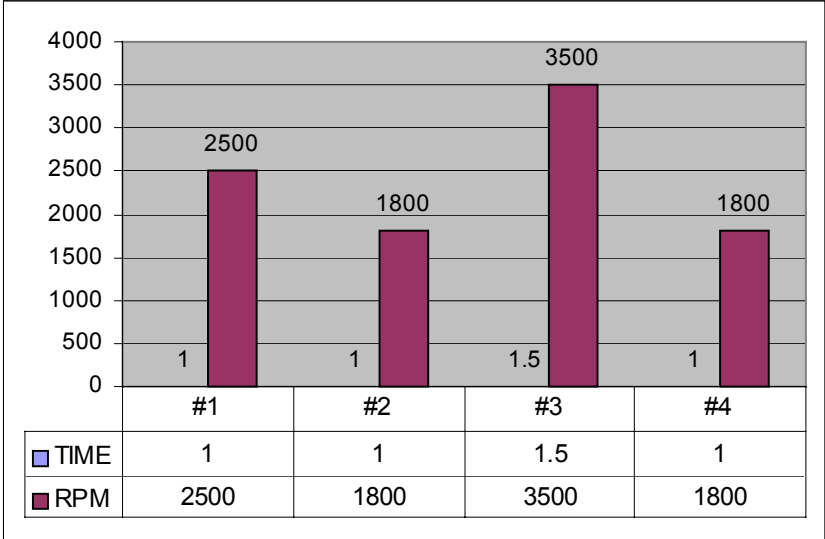

**Now that you have completed step one, Step two is to increase the revolutions of the engine in increments of 1000 rpm every five seconds up to full throttle and maintain full throttle for one full minute. During this time monitor the EGT (max 1250F) and CHT (max 500F) then reduce the rpm in increments of 1000 rpm every ten seconds down to idle. This concludes the break in period.**

**This engine is built with a ceramic coated cylinder lining and does not require extensive break-in time. However, it is recommended for the first two hours of use to avoid prolonged full throttle.**

**Best performance of this engine will be attained after the first ten hours of use.**

Any irregularities in the engine speed may be caused by a badly adjusted carburettor. After the first hour of run time is complete, and engine is cooled down the cylinder head bolts must be re-torqued. And check that all other bolts are tightly fastened in accordance with the torque settings given in the table above. **(Engine must be cool)**

## **FINAL CHECK**

After having inspected all the bolts, there is one final and extremely important component to be checked: the spark plug. The spark plugs are a sufficiently reliable indication of the carburetor.

Remove the spark plugs and check the colour of the ceramic insulator at the electrode end. If it has turned a mid-brown colour, the carburetor has been adjusted correctly. Conversely, if it has turned black or dark brown, the fuel is too rich. If the ceramic is a light brown or sand colour, it means the fuel is too lean.

**Adjust the carburetor accordingly (see ADJUSTING THE CARBURETOR)**

Remember that an excessively rich blend will not cause any immediate problems to the engine except that carbon deposits will form prematurely. Too weak or lean a blend, however, may cause irreversible damage to the cylinder and piston.

The engine is now ready to be used as intended.

## **START UP PROCEDURE**

Ensure the contact is on “start” and that you are able to disconnect the circuit immediately, if necessary. Allow fuel to enter the fuel lines and carburetor by using your plunger primer.

Adjust the throttle position about 20% , Press the starter button until the engine starts (press no more than 4 to 5 times, taking care not to overheat the starter motor).

After starting the engine, reduce the throttle gradually and disengage the starter as soon as possible (prolonged use of the starter may damage the motor).

If the engine does not start, check the spark plug caps are secure and that the switch is on “start”. If nothing still happens, remove and inspect the spark plugs.

- If the spark plug is damp, the engine is flooded. Remove the spark plugs, disengage the ignition and use the starter to crank the engine to discharge any excess fuel in the cylinders. Replace the spark plugs after having dried them and repeat the starting procedure.

## **HOW TO USE THE ENGINE**

Switch on the engine **following the start up instructions**.

Wait until the head temperature reaches around 100°C (212 °F), at this point you can use the engine up to full power checking that the CHT does not go over 260°C (500°F).

When you reduce the RPM, it is normal that CHT may increase a bit for a few seconds in order to dissipate normal internal temperatures.

The air cooled engine is different from the liquid cooled engines in that the CHT temperature will fluctuate so it is very important to monitor the CHT temperature at all times.

## **ADJUSTING THE CARBURETOR**

### **Choke and idle adjustment.**

#### **1- Choke adjustment.**

Before adjusting the idle, ensure that the choke screw is adjusted correctly. This must be done on a warm engine; the screw is located to the left of the idling mixture adjusting screw in the main body of the carburetor.

- Switch off the engine and twist the air screw all the way (without applying excess force) then loosen by turning out the screw (1½). Turns.
- Start the engine, adjust the idler screw so the engine is running at the same speed or faster and adjust accordingly.
- To do so, turn the air screw slowly in the appropriate direction; this operation should only be attempted with the engine mounted on a test stand or by trial and error with the engine switched off, due to the proximity of the propeller.
- It may be necessary to give the screw a ½ turn more or less than the prescribed amount.

#### **2- Idle adjustment.**

The minimum number of revs is 1500 rpm. If the idle is not adjusted correctly, the engine will run irregularly. To adjust, turn the large, external screw in or out accordingly.

### **Throttle cable**

- Once the throttle cable has been fitted, adjust the freeplay between the carburetor and the throttle lever by acting on the tensioning device.
- Set the throttle lever to minimum.
- Check that the carburetor slide is free to move and that the cable sheath has less than 1 mm of freeplay (check by pulling the sheath). If necessary, adjust the cable adjusting nuts to achieve the proper end play.
- Check that the two carburetors open at the same time. **It is advisable at this time to sync-nize your carburetor use an appropriate carb sync tool.**

### **Choke cable.**

The choke cable should have 2-3 mm of freeplay so that the slide is completely free when the choke is not in use. Adjust by acting on the relative tensioning device.

## **STOP PROCEDURE**

Before switching off the engine, maintain a minimum 2000-2500 RPM this will allow a cool down period and allow that the CHT temperatures to reduce to 150 °C (302°F), then reduce the throttle to minimum, wait a few seconds, and then shut down the engine. If you follow this procedure during each engine shut down this will help your engine TBO.

## **THE GEAR DRIVE**

### **Function of the gear drive**

Two-stroke engines are designed in such a way as to generate full power at a high number of revs, namely, 6000 rpm or higher. At these speeds, the performance of the propeller would be unsatisfactory on account of its small diameter and would produce an unacceptable amount of aerodynamic noise on account of the speed of rotation.

The only way of reducing the noise and boosting performance is to fit a gear reducer between the engine and the propeller

### **Choosing the right reduction.**

This engine is sold with mechanical gear reduction which includes helical gears. We choose this type of gear for the minimum noise it makes and for the power it can give in a compact size. Our gear reduction also includes a centrifugal clutch. This combination helps rid any misalignment and therefore aid in reducing vibration. Further more the clutch reduces the dangerous torsion movements to the crankshaft during the start-up procedure.

At start-up the propeller is able to free wheel and becomes engaged only when the RPM of the engine reaches in excess of 1900-2100 RPM per minutes. The gear couple works in an oil bath therefore check the level of the oil and change the oil after the firsts 5 hours of work. And every 200 hours thereafter. Use only high quality gear oil SAE-90 or SAE 80-120. The level is up to the lower front plug.

## TROUBLE SHOOTING

Whatever model you choose, the engine will only function if:

- good spark is produced
- and you have proper air/fuel mix.

Often, the majority of problems arise when one of the above conditions is lacking. Get organised and follow a strict procedure in order to identify the problem. Finding the problem must be a logical process. Below is a brief trouble-shooting guide.

### 1. THE ENGINE WON'T START!

Probable cause:	Remedy:
Ignition failure.	Turn the switch to ON.
The fuel flow valve is closed or the filter is blocked.	Open the valve, clean or replace the filter and check the fuel lines for any leaks.
The fuel tank is empty.	Re-fuel.
You have not followed the start up procedure correctly.	Repeat the process, following the instructions carefully.
The spark plug is flooded as a result of supplying too much fuel when starting up the engine.	Remove and clean the spark plugs, run the engine using the electric starter with the throttle wide open for 5 seconds then replace the spark plugs.
The spark plug is damp on account of excessive condensation.	Dry the spark plug carefully.
The spark plug electrodes are further apart than the recommended distance.	Adjust electrodes so that the distance is 0.7mm as indicated in the technical specifications.
The electrodes are worn away.	Replace the spark plugs.
The spark plug is dirty (oil and lead deposits on the insulator).	Clean the spark plug carefully using a metal brush or replace, as necessary.
The high tension lead is badly connected, loose or damaged.	Connect the cable or check it is in good condition, as appropriate.
The engine turns too slowly when starting-up on account of the electric starter motor battery is low or defective.	Re-charge or replace the starting battery.
The float valve is dirty or blocked.	Clean or replace the float valve.
Fuel spray nozzles are blocked.	Clean the spray nozzles.
There is water in the carburetor (carburetor with float) or at the bottom of the fuel tank.	Change the oil and clean the carburetor, the carburetor piping, filter and fuel tank.
Insufficient compression or damaged engine.	Contact your local dealer.

## 2. PROBLEM: INCONSISTENT IDLE

Probable cause	Remedy:
The starter motor is switched on.	Switch off the starter motor.
Badly adjusted carburetor/s.	Adjust the carburetor/s.
The float valve is dirty, blocked or worn.	Clean or replace the float valve.
The inlet manifold is leaking.	Tighten the joint, replace any faulty parts.

## 3. PROBLEM: THE ENGINE IS RUNNING IRREGULARLY

Probable cause:	Remedy:
Defective spark plug.	Check the spark plug, clean it inside and out, adjust the distance between the electrodes. Replace if necessary.
Defective or damp high tension lead.	Dry any damp cables or replace the damaged cable if it cannot be repaired.
Faulty spark coil.	Replace with an identical coil; do not change model.
Fuel or air filters are obstructed.	Clean or replace the filters.

## 4. THE ENGINE HAS STOPPED

Probable cause:	Remedy:
The fuel tank is dry.	Re-fuel.
The fuel lines are blocked.	Clean the fuel filter.
The ignition is cut off after contact has been made.	Check the wiring system and the stop switch.
The engine will not start up again.	See point 1. Alternatively, the spark coil is completely unusable. Replace.



**5. PROBLEM: THE PERFORMANCE OF THE ENGINE  
IS UNSATISFACTORY**

<b>Probable cause:</b>	<b>Remedy:</b>
The recommended fuel mix has not been used.	Check the fuel mix.
Insufficient fuel feed.	Check the fuel feed and clean the fuel filter if necessary.
The air filter is dirty.	Clean or replace the air filter.
The air inlet is leaking.	Tighten all joints, check the carburetor joints for air-tightness.
Carburetor diaphragm (for engines fitted with diaphragm carburetors).	Replace the diaphragm.
No ignition.	The ignition system is faulty. Check the ignition circuit. Adjust the ignition.
Bad carburation.	Check the carburetor adjustments.

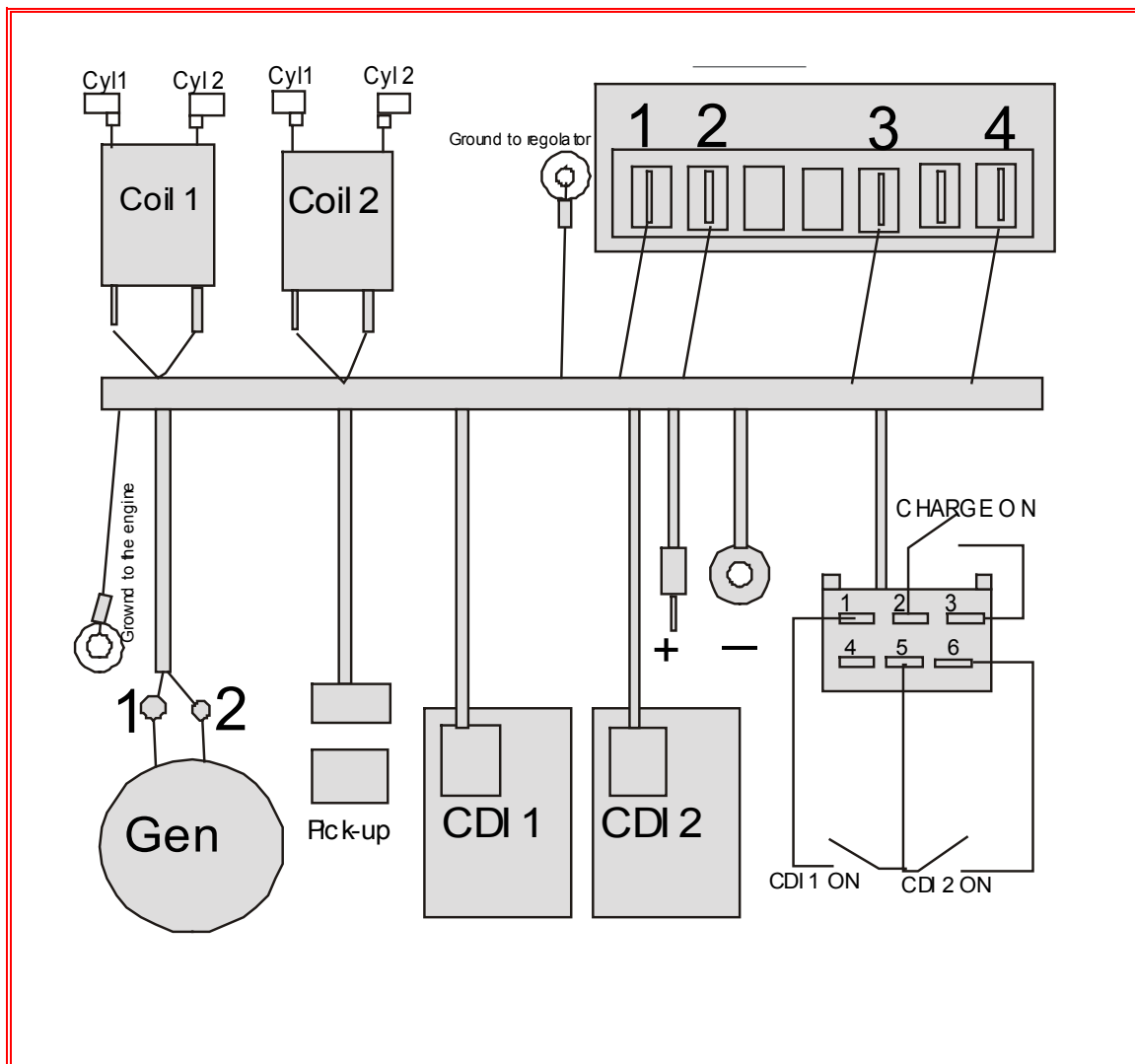

The white connector must be connected as shown in the drawing:

N°2 with N°3

N°5 with 6 and 1

Connect one ground cable to the engine

One ground cable to the regulator

One ground cable to the battery

Connect the "+" wire directly to the battery

Engine must run with the switch closed - Regulator must charge with the switch closed

### WARNING

**The engine is supplied with a preassembled wiring harness.**

**Ensure the battery cables are securely soldered to the terminals.**

Bad connections will lead to wire over-heating and irreversible damage to the battery. If you wish to be able to disconnect the battery, cable connectors of the right size may be used. Remember that the battery generates 700amps if a short circuit occurs.

When connecting the battery and start-up motor, always ensure the gauge of the cables is adequate; if the cables used are too small, this could lead to a drop in voltage which will make it more difficult to start the motor and cause the cables to over-heat and melt.

**MZ202 ENGINE  
MAINTENANCE  
SCHEDULE**

Checks and work to be carried out (hours)	1	9	12	25	50	75	100	125	150	175	200	225	250	275
1) Tighten the cylinder head screws	X				X		X		X		X		X	
2) Check the starter cable			X											
3) Check the starter ring gear			X		X		X		X		X		X	
4) Check the spark plug			X											
5) Replace the spark plug				X	X	X	X	X	X	X	X	X	X	X
6) Check and clean the spark plug cap			X											
7) Check the ignition alternator						X			X			X		
8) Check gearbox oil	X				X		X		X		X		X	X
9) Replace exhaust springs							X		X		X			
10) Grease control cables				X	X	X	X	X	X	X	X	X	X	X
11) Check balance and tracking of propeller				X	X	X	X	X	X	X	X	X	X	X
12) Replace propeller fastening screws							X				X			
13) Clean air and fuel filters, lubricate air filter				X	X	X	X	X	X	X	X	X	X	X
14) Replace fuel filter (do not use paper filters)							X				X			
15) Check the carburetor, adjust idle setting and cable tension	X			X		X		X		X		X		X
16) Clean carburetor and check the condition of the idle pipe					X		X		X		X		X	
17) Replace float pointer									X					
18) Clean and check the fuel pump						X			X			X		
19) Check the cylinder head and piston (remove encrustation if thicker than 0.5 mm), replace gaskets.					X		X		X		X		X	
30) Check wear and freeplay of components					X		X		X		X		X	
<b>THE ENGINE SHOULD BE GIVEN A COMPLETE OVERHAUL EVERY 500 HOURS (CONTACT YOUR DISTRIBUTOR)</b>														

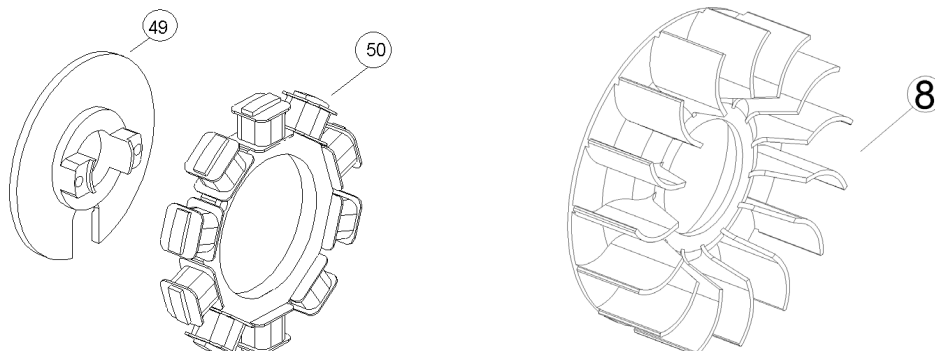



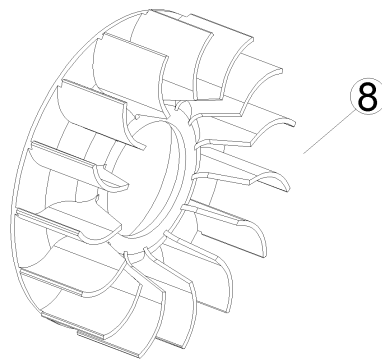
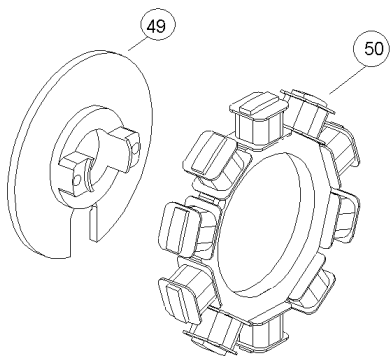
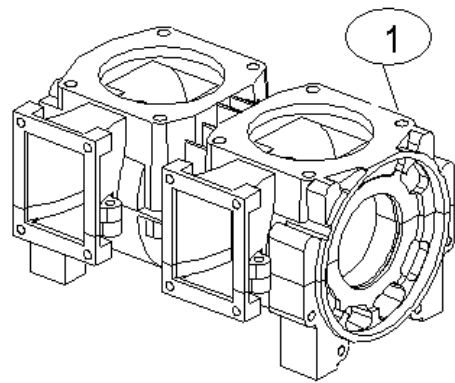
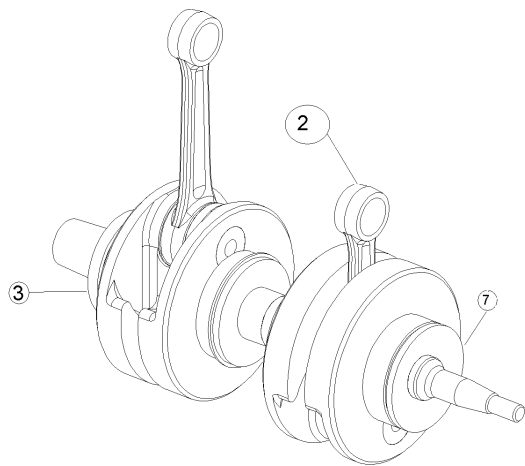
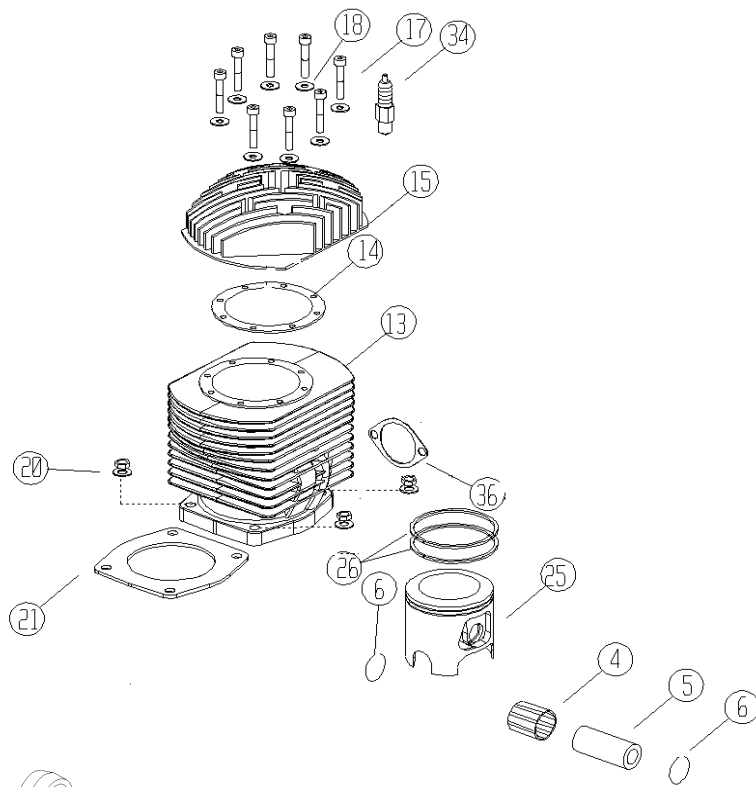

N°	Code	Q.ty	Description	N°	Code	Q.ty	Description
1.	202001	1	CRANKCASE	29	3410029	2	TCEI 6x50 UNI5931 SCREW
2.	202002	1	CRANKSHAFT	30	3410030	18	SCHNOR D.6 WASHER
3.	202003	1	BEARING PTO SIDE	31	3410031	1	25x47x7 GAS RING
4.	340004	2	PIN ROLLER CAGE	32	3410032	2	INTAKE GASKET
5.	341005	2	PISTON PIN	33	3410033	1	FLYWHEEL KEY
6.	341006	4	PIN RETAINER	34	3410034	4	TCEI 6x20 UNI 6912 SCREW
7.	202007	1	BEARING ROTOR SIDE	35	2020035	1	ELECTRIC STARTER
8.	202008	1	FAN COMPLETE WITH ROTOR AND GEAR	36	3410036	2	EXHAUST GASKET
9.				37.	3410037	1	EXHAUST MANIFOLD
10.	3410010	2	REED VALVE	38.	3410038	4	8x25 SCREW FOR EXHAUST MANIFOLD + SPRING CONNECTION
11.	3410011	2	RUBBER INTAKE MANIFOLD	39.	3410039	3	EXHAUST SPRING
12.	2020012	8	25x75x15x8 CYLINDER SCREW BOLTS	40.	3410040	2	SCHNOR D.8 WASHER
13.	3410013	2	CYLINDER	41	2020041	1	ALLUMINIUM AIR BOX
14.	3410014	2	CYLINDER HEAD GASKET	42	2020042	1	PLASTIC FAN BOX COVER
15.	3410015	2	CYLINDER HEAD	43	2020043	1	AIR GUIDE
16.	202004		FUEL DISTRIB + COIL SUPPORT	44	2020044	1	EXAUST MANIFOLD
17.	3410017	8	TCEI 6x35 UNI 5931 DIN912 SCREW	45	2020045	1	SILENCER
18.	3410018	12	D.6 WASHER	46	2020046	2	DOUBLE COIL
19.	3410019	8	M8 NUT	47	2020047	1	WIRING CABLE
20.	3410020	8	D.8 WASHER	48	2020048	2	CDI BOX
21.	3410021	2	CYLINDER GASKET	49	2020050	1	GENERATOR SUPPORT
22.	3410022	1	PRESSURE TUBE CONNECTION	50	2020051	1	180W GENERATOR
23.	3410023	1	6x8x1 ALUMINIUM GASKET	51	2020052	1	POWER REGULATOR
24.	3410024	1	25x52x7 GAS RING				
25.	3410025	2	PISTON				
26.	3410026	4	PISTON RINGS				
27.	3410027	4	TCEI 6x20 UNI 5931 SCREW				
28.	3410028	4	TCEI 6x45 UNI 5931 SCREW				Preliminary spare parts list

<b>Daily checks</b> <b>(To be carried out as part of the preliminary flight inspection at the beginning of each flying day)</b>
Check the electrical contact is on “stop”.
Remove any water contained in the fuel tank.
Check the inlet manifold and the carburetor are securely fitted. <b>Warning: a cracked inlet manifold will cause piston failure.</b>
Check the carburetor float chamber (water, impurities).
Check the conditions, cleanliness and attachment of the air filter.
Check the cylinder head and the cylinder housing for leakage’s.
Check that the attaching components for the ignition coil and electrical connections are secure.
Check the electric starter motor is secure (cracks, screws and connections ...).
Check the engine is attached securely to the frame (silent block mountings and screws).
Check the reduction and attaching bolts of the starter motor
Check the fuel lines and all related hoses.
Turn the engine manually and listen for any unusual noises (to be carried out with the electrical contact switched off)
Check the bearings of the reduction by rotating the propeller by hand (to be carried out with the electrical contact switched off)
<b>Inspection to be carried out prior to flying (Before every flight)</b>
Check the ignition switch for on/ off
Check the fuel level
Check that the spark plug caps are secure
Check that there are no screws, nuts or other components missing from the engine and gear box.
Check the propeller (repair or replace if cracked or chipped)
Check the propeller fastening screws
Check that the choke and contact block controls are locked well into place.
Check the exhaust head (cracks, bolts, springs, brake cables...)
Switch the engine on after having checked that there is nobody in the vicinity
Check the idle contact
Check the dual engine ignitions, check each individually
Check the instruments while the engine is warming up





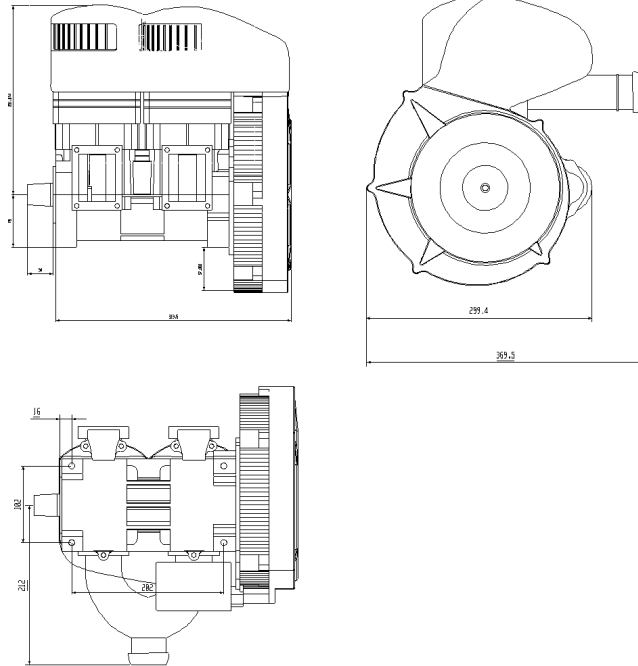

## **Compact Radial Engines**

**Inc.**

**#3-8473 124<sup>th</sup> Street  
Surrey, B.C.**

**Canada. V3W-9G4**

**Phone: (604)590-2950**

**Fax: (604)590-8814**

[www.compactradialengines.com](http://www.compactradialengines.com)

[m](mailto:info@compactradialengines.com)

## **FRANCE and Benelux:**

**ULM Tecnology SARL**

**Aerodrome de Valenciennes**

**F - 59 121 Prouvy**

**Phone (0)327 45 53 53**

<http://www.ulmtechnologie.com>

**03-19-02**